

Technical reference guide

Non-metallic materials for use in underground coal mines and reclaim tunnels in coal mines

MDG 3608

October 2022

Published by the Department of Regional NSW

Title: Technical reference guide: Non-metallic materials for underground coal mines and reclaim tunnels in coal mines

First published: January 2007

Department reference number: DOC18/912541

Amendment schedule		
Date	Version	Amendment
January 2007	First	Published as draft MDG3608 MTR 8.
August 2012	Second	Published as MDG3608.
November 2020	Third	Renamed technical reference guide, new template, updated to reflect current legislative framework and removed references to alternative equivalent testing being approved by the Chief Inspector.
October 2022	Fourth	Major revision to document.

© State of New South Wales through Regional NSW 2022. You may copy, distribute, display, download and otherwise freely deal with this publication for any purpose, provided that you attribute Regional NSW as the owner. However, you must obtain permission if you wish to charge others for access to the publication (other than at cost); include the publication in advertising or a product for sale; modify the publication; or republish the publication on a website. You may freely link to the publication on a department website.

Disclaimer: The information contained in this publication is based on knowledge and understanding at the time of writing (October 2022) and may not be accurate, current or complete. The State of New South Wales (including Regional NSW), the author and the publisher take no responsibility, and will accept no liability, for the accuracy, currency, reliability or correctness of any information included in the document (including material provided by third parties). Readers should make their own inquiries and rely on their own advice when making decisions related to material contained in this publication.

Table of Contents

1. Purpose and scope.....	9
1.1. Purpose	9
1.2. Scope.....	9
1.3. References	9
1.4. Abbreviations	9
1.5. Definitions.....	9
1.5.1. Brattice.....	9
1.5.2. Conveyor accessories.....	10
1.5.3. May.....	10
1.5.4. Oxygen Index testing	10
1.5.5. Production acceptance testing	10
1.5.6. Shall.....	10
1.5.7. Should	10
1.5.8. Surveillance testing.....	10
1.5.9. Testing.....	10
2. General	11
2.1. FRAS properties.....	11
2.1.1. Fire resistance	11
2.1.2. Static electricity.....	11
2.2. Quality management systems.....	11
2.3. Type testing	11
2.3.1. General.....	11
2.3.2. Type testing facility.....	12
2.3.3. Alternative equivalent type tests	12
2.3.4. Changes to product manufacture.....	12
2.3.5. Changes to product performance.....	12
2.3.6. Type test report.....	12
2.4. Production acceptance testing.....	13
2.4.1. General	13
2.4.2. Production acceptance test records	14
2.5. Duties	14
2.5.1. Designer	14
2.5.2. Manufacturer	14
2.5.3. Importer and supplier	15
2.5.4. Mine operator	15
2.6. Markings	16
3. Conveyor belting and accessories.....	16

3.1. General.....	16
3.2. Conveyor belting.....	16
3.2.1. Design.....	16
3.2.2. Type testing.....	16
3.2.3. Production acceptance testing.....	16
3.2.4. Supply and use.....	17
3.3. Conveyor accessories.....	17
3.3.1. Design.....	17
3.3.2. Type testing requirements.....	17
3.3.3. Production acceptance testing.....	18
3.4. Belt splicing kits and belt repair kits.....	18
3.4.1. Design.....	18
3.4.2. Type testing requirements.....	18
3.4.3. Production acceptance testing.....	18
3.5. Non-metallic conveyor idlers and lagged conveyor idlers.....	19
3.5.1. Design.....	19
3.5.2. Type testing.....	19
3.5.3. Production acceptance testing.....	20
3.6. Non-metallic conveyor structure.....	20
3.6.1. Design.....	20
3.6.2. Type testing.....	20
3.6.3. Production acceptance testing.....	21
3.7. Slider impact bars.....	21
3.7.1. Design.....	21
3.7.2. Type testing.....	21
3.7.3. Production acceptance testing.....	22
4. Ventilation components and accessories.....	22
4.1. General.....	22
4.2. Ventilation sheet (brattice).....	22
4.2.1. Design.....	22
4.2.2. Type testing.....	23
4.2.3. Production acceptance testing.....	23
4.3. Non-metallic flexible ventilation ducting.....	24
4.3.1. Design.....	24
4.3.2. Type testing.....	24
4.3.3. Production acceptance testing.....	25
4.4. Non-metallic rigid ventilation ducting.....	25
4.4.1. Design.....	25

4.4.2. Type testing	25
4.4.3. Production acceptance testing	26
4.5. Joining bands for non-metallic ventilation ducting	26
4.5.1. Design	26
4.5.2. Type testing	26
4.5.3. Production acceptance testing	27
5. Other defined applications	27
5.1. Air / water hose	27
5.1.1. Design	27
5.1.2. Type testing	27
5.1.3. Production acceptance testing	27
5.2. Hydraulic hose	27
5.2.1. Design	27
5.2.2. Type testing	27
5.2.3. Production acceptance testing.....	28
5.3. Grid mesh	28
5.3.1. Design	28
5.3.2. Type testing	28
5.3.3. Production acceptance testing	28
5.4. V-belts and wedge belts	29
5.4.1. Design	29
5.4.2. Type testing	29
5.4.3. Production acceptance testing	29
5.5. Rib/roof bolts.....	29
5.5.1. Design	29
5.5.2. Type testing	29
5.5.3. Production acceptance testing	30
5.6. Flexible intermediate bulk containers (FIBC).....	30
5.6.1. Design	30
5.6.2. Type testing	30
5.6.3. Production acceptance testing	30
5.7. Bags used for explosion barriers (bat bags).....	31
5.7.1. Design	31
5.7.2. Type testing	31
5.7.3. Production acceptance testing	31
5.8. Non-metallic pipe.....	31
5.8.1. Design.....	31
5.8.2. Type testing.....	31

5.8.3. Production acceptance testing	32
6. Non-defined applications	32
6.1. Risk management.....	32
6.2. Design	33
6.3. Type testing	33
6.3.1. Fire resistance	33
6.3.2. Oxygen index.....	34
6.3.3. Antistatic properties (electrical resistance).....	34
6.3.4. Toxicity of products of combustion.....	34
6.3.5. Production acceptance testing	34
Appendix A - Associated documents.....	35
1. The control of undesirable static electricity	35
2. International Standards (ISO and IEC).....	36
3. National Coal Board Standards United Kingdom (NCB).....	36
4. Other publications.....	36
Appendix B – Non-metallic conveyor idler tests	37
Flame propagation of non-metallic and lagged conveyor idlers test	37
1. Method.....	37
1.1.1. Scope	37
1.1.2. Principle	37
1.1.3. Application to fire hazard.....	37
1.1.4. Apparatus.....	37
1.1.5. Test pieces	38
1.1.6. Procedure.....	38
1.1.7. Report	38
1.2. Requirements	38
2. Ignitability and surface temperature - component subject to friction test.....	38
2.1. Method.....	38
2.1.1. Scope.....	38
2.1.2. Principle	38
2.1.3. Test criteria	39
2.1.4. Application to fire hazard	39
2.1.5. Apparatus.....	39
2.1.6. Test pieces.....	40
2.1.7. Procedure	40
2.1.8. Report	40
Appendix C – Test methods.....	41
1. One kilowatt burner flame test.....	41

1.1. Method.....	41
1.1.1. Test pieces.....	41
1.1.2. Test apparatus.....	41
1.1.3. Procedure.....	42
1.1.4. Expression of results	42
1.2. Requirements	43
2. Spirit lamp test.....	43
2.1. Method.....	43
2.1.1. Test pieces.....	43
2.1.2. Apparatus.....	44
2.1.3. Spirit lamp.....	44
2.1.4. Procedure	44
2.1.5. Expression of results	44
2.2. Requirements	45
3. ‘Follow-up’ flame test.....	45
3.1. Method.....	45
3.1.1. Test pieces.....	46
3.1.2. Apparatus.....	46
3.1.3. Procedure.....	46
3.1.4. Expression of results	47
3.2. Requirements	47
4. Electrical resistance of flat surfaces test.....	47
4.1. Method.....	47
4.1.1. Test pieces.....	47
4.1.2. Preparation of test pieces.....	47
4.1.3. Apparatus.....	48
4.1.4. Test procedure.....	48
4.1.5. Expression of results	49
4.2. Requirements	49
5. Electrical resistance of rigid pipes and rods test	49
5.1. Method.....	49
5.1.1. Principle of test.....	50
5.1.2. Measuring instrument.....	50
5.1.3. Sampling.....	50
5.1.4. Test pieces	50
5.1.5. Preparation of test pieces.....	50
5.1.6. Test procedure.....	50
5.1.7. Expression of results	51

5.2. Requirements	51
6. Air permeability of brattice test.....	51
6.1. Method.....	51
6.1.1. Test pieces.....	51
6.1.2. Apparatus.....	51
6.2. Requirement.....	52
7. Toxicity testing.....	52
7.1. Method.....	52
7.2. Requirements	53
8. Spark incendivity	53
8.1. Method	53
8.1.1. Test piece.....	53
8.1.2. Apparatus.....	53
8.1.3. Ambient conditions	54
8.1.4. Test procedure.....	54
8.2. Requirements	54

1. Purpose and scope

1.1. Purpose

The purpose of the document is to minimise risks to health and safety of people from the use of non-metallic materials. This document specifies the testing and assessment standards for determining whether an item of plant or component is fire resistant anti-static (FRAS) to manage risks associated with:

- a) accumulation of a static electric charge,
- b) fire initiation,
- c) fire propagation, or
- d) toxic products of combustion.

NOTE: For the purposes of this document, a non-metallic material is considered to be FRAS if it complies with the applicable FRAS assessments detailed in this document.

1.2. Scope

This document covers the general risk controls and testing of non-metallic materials intended for use in underground coal mines. It also covers conveyor belting and accessories in reclaim tunnels at coal mines.

NOTE: This document is intended to assist in the evaluation of risk and may not comprehensively cover all safety-related aspects of the use of non-metallic materials.

1.3. References

A list of documents referenced in this document is included in Appendix A.

1.4. Abbreviations

For the purpose of this document the abbreviations below apply:

AS	Australian Standards
AS/NZS	Australian Standards/New Zealand Standards
IAF MLA	International Accreditation Forum Multilateral Recognition Arrangement
ILAC MRA	International Laboratory Accreditation Cooperation Mutual Recognition Arrangement
ISO	International Organization for Standardization
FRAS	Fire resistant anti-static
JAS-ANZ	Joint Accreditation System of Australia and New Zealand
NATA	National Association of Testing Authorities
PCBU	Person conducting a business or undertaking
QMS	Quality Management System

1.5. Definitions

For the purpose of this document the definitions below apply.

1.5.1. Brattice

Any flexible curtain or material that is used for partitioning ventilation circuits for the purpose of directing ventilating air within a mine.

1.5.2. Conveyor accessories

Non-metallic components that may make contact with a moving conveyor belt. For example, this includes, but not limited to, scraper blades, ploughs, skirt rubbers, pulley lagging, component parts of belt tracking systems, belt splicing kits and belt repair kits

NOTE: Non-metallic components in large quantities such as non-metallic conveyor idlers, lagged idler rollers and conveyor structure are not considered 'conveyor accessories'.

1.5.3. May

Indicates an optional course of action that this guide is indicating should be considered. However, an alternative method of achieving a safe system of work may be chosen.

1.5.4. Oxygen Index testing

Oxygen index testing determine a materials tendency to sustain a flame. A product with an oxygen index greater than 28% can be considered self-extinguishing. Oxygen index testing has been adopted in conveyor manufacturing standards as a measure of consistency of manufactured products. Refer to <https://documents.uow.edu.au/~mnelson/review.dir/oxygen.html> for further information.

1.5.5. Production acceptance testing

Testing of production runs of non-metallic materials to verify that the manufactured product continues to perform as per the type tested samples.

NOTE: This may also be known as batch testing or routine testing.

1.5.6. Shall

Indicates a requirement that has to be complied with where compliance with this guide is sought.

1.5.7. Should

Indicates a recommended course of action.

NOTE: Deviations from recommendations should be provided with a respective management control, shown to provide the same level of safety outcome.

1.5.8. Surveillance testing

Testing of random samples taken from the field for to verify that there has been no deterioration or loss of performance characteristics.

1.5.9. Testing

NOTE: The following definitions are from AS 60695.6.1-2006 (Withdrawn)

1.5.9.1. Large scale testing

A test that exceeds that of a typical laboratory bench test.

1.5.9.2. Small scale testing

A test which may be made on a typical laboratory bench.

1.5.9.3. Real scale testing

A test which simulates an end-user situation in both size and surroundings.

1.5.9.4. Type testing

Testing of samples of a product to ensure the product conforms to the specified design requirements and standards.

NOTE: Type testing is analogous to conformance testing.

1.5.9.5. Ventilation products and accessories

Includes ventilation appliances and accessories, ventilation sheet (including brattice), non-metallic flexible ventilation ducting, non-metallic rigid ventilation ducting.

2. General

2.1. FRAS properties

2.1.1. Fire resistance

Fire resistance materials are those that when exposed to a flame or heat source are difficult to ignite. Once the flame/heat source has been removed, combustion of the product ceases. A product that is determined to be fire resistant should not be considered fireproof as the product may combust while an external flame or heat source is applied. A fire resistant product should never be the source of a fire and should not be the fuel that propagates a fire.

2.1.2. Static electricity

Australian Standard AS/NZS 1020 - The control of undesirable static electricity provides technical information on the mechanisms of how static charge is generated and stored. In underground coal mines any air stream, whether resulting from mine ventilation or released from a pressurised source, should be considered a source of static electricity.

The risk of a gas ignition is realised when an accumulated charge is rapidly discharged in a flammable atmosphere. To prevent this, materials that are not capable of accumulating and storing an electric charge should be used. Where this is not possible, material used should be able to dissipate an electric charge more quickly than it can be accumulated. This also requires secure connections to earth that do not result in sparking.

Some materials are able to store a charge but due to their high resistance may not dissipate a charge quickly enough to cause a spark. The addition of highly conductive attachments that are not themselves connected to earth, such as metal eyelets in ventilation ducting or dust and ventilation curtains, can become a source of sparking capable of igniting flammable gas. In these situations, it is essential that any discharge bonding conductors have a resistance low enough that any electric charge is dissipated faster than it can accumulate.

Guidance in respect of the control of undesirable static electricity is contained in AS/NZS 1020. These factors should all be considered when determining what level of risk an application presents and what properties a material should have to prevent static discharges capable of igniting flammable gasses.

2.2. Quality management systems

A facility for the manufacture of FRAS products in accordance with this document shall have a quality management system (QMS) that complies with (AS/NZS) ISO 9001. The system should be certified by a JAS-ANZ accredited body or a signatory to the IAF MLA for QMS.

The scope of the QMS shall include the manufacturing process related to the product. Where testing is carried out at the facility, testing shall also be included in the scope of the QMS.

2.3. Type testing

2.3.1. General

Type testing is undertaken by an independent testing facility for the manufacturer to verify that the design meets the design specification and meets or exceeds the minimum performance requirements detailed within this document. It does not apply to each individual product that is subsequently manufactured.

Type testing shall be undertaken as identified for each type of product specified below. The type testing shall include testing in accordance with the production acceptance tests nominated in the manufacturer's QMS for the product samples provided for type testing.

Where a range of product of identical material and construction is produced i.e. hydraulic hose, type testing only needs to be undertaken on a sample range of sizes. As a minimum, this shall include the smallest and largest samples of product, and should include some intermediate sizes where there is a large range. Not every size within the range is required to be tested.

2.3.2. Type testing facility

The test facility used for type testing shall be a test facility unrelated to the organisation designing or manufacturing the product. The test facility shall be accredited to ISO/IEC 17025 for performing the specific tests described in this document and either be:

- a) accredited by NATA, or
- b) an organisation that is accredited by a signatory to the ILAC MRA, or
- c) where (a) or (b) do not exist, a suitably qualified and experienced independent testing facility with regard to test equipment, equipment calibration, quality processes, work methods, past test experience and independent technical verification.

Where the testing is undertaken by a facility in accordance with (c) above, the designer/manufacturer must retain records of why this facility was chosen in place of a test facility meeting either (a) or (b) and how the facility demonstrated that it met all necessary requirements.

2.3.3. Alternative equivalent type tests

Alternative equivalent tests to those specified in this document may be used provided the alternative test verifies that an equivalent level of safety is achieved. The manufacturer shall identify and document the rationale and reason for equivalence.

The alternative equivalent test shall still be completed by a test facility complying with 2.2.2.

Where an alternative test is being used to determine compliance, this must be communicated to the end user.

2.3.4. Changes to product manufacture

Any change to the raw materials or the manufacturing process may affect the performance of a manufactured product. As such, any change to the specification or quantities of raw material, or to the manufacturing process which may affect the performance requires the product to undergo type testing to verify the product still conforms to the original design specification.

2.3.5. Changes to product performance

Where the designer, manufacturer, importer, supplier or end user becomes aware the performance of the manufactured product may no longer meet the design specification, samples of the product shall be type tested to confirm the level of conformity with the design specification.

Where change to product performance is identified at any time during the lifecycle of the product, the design of the product and the manufacturing process shall be reviewed to identify and correct for the performance change.

2.3.6. Type test report

A type test report(s) shall only be issued when all samples pass the required testing identified in this document.

NOTE: It may necessitate multiple reports if more than one test facility is used.

The test report(s) shall summarise the results contained in the test report for the type testing.

The test report(s) shall contain as a minimum:

- a) identification of the test facility,
- b) a detailed description of the product tested,
- c) details of the manufacturer of the product,
- d) the results of each test undertaken including the representative production acceptance test results,
- e) time and date of test, and
- f) details of the person authorising the issue of the test report.

2.4. Production acceptance testing

2.4.1. General

Unless stated otherwise in the Production acceptance testing section for a specific product type listed below, the manufacturer shall determine appropriate production acceptance tests and frequencies based on the product that they are manufacturing, batch size and frequency of manufacturing. The testing should consider the likelihood and consequence of:

- variations due to consistency of raw material,
- human error associated with equipment configuration and manufacturing tasks,
- equipment reliability and consistency of performance,
- frequency of manufacturing tasks.

The production acceptance testing requirements, including acceptable product variation tolerances, shall be determined by the manufacturer prior to type testing and documented in the QMS. These tests may take the form of the type tests specified in this document (such as finger burn and oxygen index) or may be alternate tests that demonstrate compliance with the type tested design. This may include tests on physical properties such as product hardness, flexibility, electrical testing or chemical composition testing that indicate an unacceptable change has occurred somewhere in the manufacturing process.

Where tests other than those specified in this document, such as physical properties of the material are identified for the production acceptance tests, these tests shall be undertaken by the type testing laboratory at the time of type testing, on the same batch that is used for type testing, and the test results recorded in the type test report.

Production acceptance tests shall be undertaken in accordance with the documented production acceptance test methods. This test may be undertaken by the manufacturing facility or by another party. It is not mandatory to be completed by a test laboratory as defined in section 2.2.2, although a client may specify that they want testing done to a higher and more detailed level. The test results shall align with the results detailed in the type test report for the product. The QMS shall determine how the production acceptance test results are documented. These results must be made available on request of the end user.

Where a FRAS product is used to manufacture a final product, such as ventilation or dust curtain, ventilation ducting, non-metallic conveyor structure or some conveyor accessories, the production acceptance tests completed by the product manufacturer do not need to be repeated so long as the production acceptance test report for the FRAS product used is available to be provided to the purchaser of the final product if requested.

In some situations, manufacture may be undertaken by multiple organisations. For example, a base product such as ventilation sheeting is manufactured by one organisation. This sheeting is then used to manufacture a finished product such as a dust curtain or lay flat ventilation ducting. In this situation, the manufacturer of the base product will provide a report addressing all relevant testing criteria for that product to the finished product manufacturer. The manufacturer of the finished product does not need to repeat tests covered by the first manufacturer as long as the first

manufacturer provides a copy of the production test report. This can then be provided with the finished product they supply.

The finished product manufacturer shall assess their process and determine what FRAS properties may have been affected during their manufacturing process. Those aspects which have resulted in changes, such as the introduction of metallic eyelets, should be retested at a type test laboratory and appropriate production acceptance tests determined and documented on the type test report.

In the example above, this would involve additional testing such as electrical resistance and spark incendivity testing. Test reports for tests that have been required to be undertaken along with the production test report from the base product manufacturer should be supplied to the end user.

2.4.2. Production acceptance test records

Production acceptance testing records shall be maintained by the manufacturer and shall be available on request.

The records shall summarise the results from the production acceptance testing.

The records shall contain, as a minimum:

- a) the testing requirements of the QMS,
- b) the acceptance criteria and results of the tests,
- c) time and date of the test,
- d) an identifier such as batch or serial number, and
- e) details of the person conducting the test.

2.5. Duties

2.5.1. Designer

In addition to duties covered in the Work Health and Safety legislation, the designer shall retain the following records while ever it is intended that product may be manufactured, or 7 years, whichever is the greater:

- a) the detailed test results from type testing,
- b) the unique identifier used to distinguish the test piece,
- c) any information specified within this document, and
- d) other supporting documents as required by quality assurance accreditation including all process control documents.

A copy of the type test report shall be provided to all manufacturers of the product.

2.5.2. Manufacturer

In addition to duties covered in the Work Health and Safety legislation, the manufacturer shall retain the following records while ever it is intended that product may be manufactured or 7 years, whichever is the greater:

- a) the test results from type testing

NOTE: This is required to enable comparison of the type tested product against subsequent production runs.

- b) the detailed results of production acceptance testing,
- c) the unique identifier(s) used to distinguish the production run,
- d) any information specified within this document, and
- e) other supporting documents as required by quality assurance accreditation including all process control documents.

A copy of the production test report shall be provided to all persons to whom the product is supplied.

2.5.3. Importer and supplier

In addition to duties covered in the Work Health and Safety legislation, the importer and the supplier shall retain the following records for at least 7 years following supply:

- a) the production test report for the batch of product,
- b) the unique identifier used to distinguish the test piece, and
- c) any information specified within this document.

A copy of the production test report shall be provided to all persons to whom the product is supplied.

Where the production test reports are not available for an imported product, the importer shall have relevant type testing undertaken on representative samples of each imported batch and provide test reports with the product.

2.5.4. Mine operator

2.5.4.1. Risk management

Where non-metallic materials are used in an underground coal mine, a risk assessment for the product or group of products must be conducted by the mine operator (Part 3.1 of the WHS Regulation). Aspects of the non-metallic material that should be considered in the risk assessment include:

- a) accumulation & discharge of a static electric charge,
- b) fire initiation and combustibility,
- c) fire propagation,
- d) the impact of products of combustion on the intended operating environment, and
- e) deterioration of fire resistant or antistatic properties due to aging, wear and tear, and damage.

Change management processes should be applied when a non-metallic material is used in a different environment or application for which it has previously been assessed for.

When the risk assessment is for the use of non-metallic conveyor idlers or structure, AS 4606:2012 Appendix D should be consulted for further information.

2.5.4.2. Testing and assessment

The mechanical engineering control plan (MECP) and the electrical engineering control plan (EECP) should detail surveillance testing programs that verify fire resistant and antistatic non-metallic material properties are not deteriorating and creating an uncontrolled risk at the mine. This testing should be undertaken at regular intervals no greater than 5 years or following an incident involving the non-metallic materials.

2.5.4.3. Records

The mine operator shall maintain a record of the test reports for the product while the product is in use at an underground coal mine or in a reclaim tunnel at a coal mine. Test reports shall include production acceptance test reports and reports of any surveillance testing undertaken on the non-metallic materials that have been in service at the mine.

These documents shall be maintained in a plant safety file. The format of the plant safety file will vary depending on the type of product being referred to. Where a FRAS item is used on a conveyor system, the test report should be added to the safety file for the conveyor.

2.6. Markings

For traceability, components shall be permanently marked, where reasonably practicable. Markings should include:

- a) an indication of being FRAS to this document (e.g. TRG FRAS)
- b) year of manufacture,
- c) manufacturer's or supplier's identification or trademark, and
- d) manufacturer's serial number or product number.

NOTE: This information could be accessible by scanning of a QR code, a barcode or some other tracking method that enables this information to be downloaded or accessed electronically.

3. Conveyor belting and accessories

3.1. General

The design of a conveyor system shall ensure that any static charge is effectively dissipated to earth without sparking. The conveyor system includes belting, idlers, structure and accessories. Where non-metallic conveyor accessories are in contact with the conveyor belting there are risks associated with combustibility (initiation and propagation of fire), static electricity (sparking) and toxicity of the products of combustion.

3.2. Conveyor belting

3.2.1. Design

All conveyor belting shall be designed to meet the requirements of Clause 6.1 of AS 4606:2012 except for type test results for oxygen index. When tested in accordance with ISO 4589-2:2017 with the covers on and with the covers off, oxygen index shall not be less than 28%. The use of commercial grade propane is acceptable.

3.2.2. Type testing

The design of conveyor belting shall be type tested in accordance with the requirements of Clauses 5.2 and 5.3 of AS 4606:2012 (as amended from time to time).

If retesting is required, this shall be undertaken in accordance with AS4606:2012, Clause 6.3.

3.2.3. Production acceptance testing

For all conveyor belting constructions, production acceptance tests shall be carried out in accordance with AS4606:2012, Clause 7.2.1.

Testing shall be conducted on every production run or at intervals of 800 metres of manufactured belt, whichever is the lesser.

The manufacturer's production acceptance test reports shall detail the results of each test and be labelled with a pass/fail in accordance with each test conducted.

Production acceptance testing shall be carried out in a testing laboratory in accordance with AS4606:2012, Clause 7.2.3.

Test results obtained during production testing shall be consistent with those obtained during type testing. For oxygen index, the results shall be within 3 percentage points of those originally obtained, but in no case be less than 28%.

Electrical resistance shall be tested in accordance with the test methods for this product, as detailed in the QMS.

3.2.4. Supply and use

3.2.4.1. Surveillance testing

Surveillance testing of in-service conveyor belting shall be undertaken in accordance with AS 4606:2012 section 8 Periodic confirmation for continued use of belt. However, testing should be undertaken at periods not exceeding 5 years. In line with the notes, it is not expected that a conveyor belt in service be removed from service or cut to take samples for testing. This testing should be opportunistic and carried out using samples taken during repair of damage, addition of new belt, etc.

No testing is required to be undertaken on conveyor belting that is in storage but shall be undertaken prior to the belting being placed into service.

3.2.4.2. Supply

A manufacturer/supplier shall not supply conveyor belting unless a sample has undergone Production acceptance testing or surveillance testing within a 5-year period.

3.2.4.3. Use

A mine that uses product that complies with this document shall maintain copies of test reports relating to the product, for the life of the product at the mine.

A mine shall not install conveyor belting unless a sample has undergone production acceptance testing or surveillance testing within a 5-year period.

A mine should have systems in place for the undertaking of routine surveillance testing of samples of conveyor belting in use at the mine.

3.3. Conveyor accessories

This does not apply to belt splicing kits or belt repair kits (refer to clause 3.4)

3.3.1. Design

The design of the accessories shall be such that effective earthing of the accessories is achieved to ensure there is no accumulation of static charge.

All non-metallic conveyor accessories shall be designed to achieve the performance requirements of Clause 6.2 of AS 4606:2012

3.3.2. Type testing requirements

All non-metallic conveyor accessories shall meet the requirements identified in Clauses 3.3.2.1 to 3.3.2.3 below.

3.3.2.1. Finger burn test

When tested in accordance with AS 1334.10, the test pieces shall meet the requirement of Clause 6.2.2 of AS 4606:2012.

If no more than two individual sample tests fail due to re-ignition from molten material hitting the gauze under the burner, the test may be redone on a full set of samples by moving the gauze from 6 millimetres to 12 millimetres, provided the test facility has sufficient samples from the same batch. This modified testing shall be noted on the test report.

NOTE: For polymers that drip under this test, the burner may be rotated 45 degrees about the longitudinal axis of the finger in order to prevent molten material falling into the burner.

For non-rubber products such as polyurethane, as an alternative test method to AS1334.10 the following tests may be carried out:

- a) IEC60695.11-10:2013. To be considered FRAS, the material must meet the requirements of classification V-0 as detailed in section 9.4.

AND

- b) IEC60695.11-20:2015. To be considered FRAS, the material must meet the requirements of classification 5VB as detailed in section 8.4.

Irrespective of what is stated in IEC60695, the result only applies for the colour and unique product tested, that is each colour or variation to material blend is required to be tested and meet the above criteria to be considered FRAS.

3.3.2.2. Oxygen index

When tested in accordance with ISO 4589-2:2017, oxygen index shall meet the requirements of Clause 6.2.3 of AS 4606:2012 but shall in no case be less than 28%. The use of commercial grade propane is acceptable.

3.3.2.3. Electrical resistance

When tested in accordance with AS 1334.9, surface and through resistance shall meet the requirements of AS4606:2012 Clause 6.2.4.

3.3.3. Production acceptance testing

Production acceptance testing shall be in accordance with the test methods for this product, as detailed in the QMS.

Where oxygen index testing is undertaken as part of the production acceptance testing detailed in the QMS, the results shall be within 3 percentage points of those originally obtained during type testing.

3.4. Belt splicing kits and belt repair kits

3.4.1. Design

All conveyor belt splicing kits and belt repair kits shall be designed to meet the requirements of Clause 6.2 of AS 4606:2012.

3.4.2. Type testing requirements

All conveyor belt splicing kits and belt repair kits shall meet the requirements identified below.

The testing of splicing materials and belting repair materials shall be performed on samples with the product applied to a FRAS conveyor belt manufactured under a type test report issued in accordance with 3.2.2 above. The belt shall have covers on and cut from one direction of belt only.

3.4.2.1. Finger burn test

Finger burn tests shall be undertaken in accordance with, and meet the requirements of, Clause 6.2.2 of AS 4606:2012.

3.4.2.2. Oxygen index

Oxygen index tests shall be undertaken in accordance with, and meet the requirements of, Clause 6.2.3 of AS 4606:2012.

3.4.2.3. Electrical resistance

Electrical resistance tests shall be tested in accordance with, and meet the requirements of, Clause 6.2.4. of AS 4606:2012.

3.4.3. Production acceptance testing

All production acceptance testing shall be in accordance with the test methods for this product, as detailed in the QMS.

The tests identified should consider the properties that can be tested during manufacture of the splice kit and that are indicative of the properties of the finished splice.

3.5. Non-metallic conveyor idlers and lagged conveyor idlers

3.5.1. Design

Non-metallic idlers and lagged conveyor idlers shall not create an unacceptable health risk to workers in the event of fire.

Non-metallic conveyor idlers and lagged conveyor idlers shall provide an effective connection to the conveyor belting to prevent the accumulation of static charge on the conveyor belting. The idler shall be able to provide this discharge path irrespective of wear or abrasion that may occur on the idler.

NOTE: For further guidance, see AS/NZS 1020:1995.

All non-metallic conveyor idlers and metallic idlers with non-metallic lagging shall be designed to achieve the performance requirements identified below.

3.5.2. Type testing

All non-metallic conveyor idlers and metallic idlers with non-metallic lagging shall be tested to meet the requirements identified in below.

3.5.2.1. Products of combustion

Each type of non-metallic material used in the conveyor idler construction shall be tested to and meet the requirements of Appendix C7 Toxicity testing.

When large scale testing is conducted, in addition to the small-scale testing requirements, smoke obscuration should be measured, where possible. Smoke obscuration testing should be conducted in accordance with AS60695.6.1:2006 or an equivalent.

The results of the tests should be used in the risk analysis when assessing impacts of fire and the determination of control measures.

3.5.2.2. Combustion propagation characteristics (gallery test)

Idlers shall undergo a gallery test in accordance with AS 1334.12:1996, modified as detailed in Appendix B1.

NOTE: The purpose of this test is to check whether the materials used prevent a fire from self-propagating along the conveyor structure or between idlers. The test may also be used to measure toxicity of products of combustion in a large-scale test and the relative change imposed by the additional non-metallic materials.

3.5.2.3. Ignitability and maximum surface temperature of idler subject to friction

A test shall be carried out to determine whether a seized idler can initiate a fire by friction between the seized or partially seized idler and the moving conveyor belting, due to excessive surface temperatures causing self-ignition or melting of the non-metallic material.

The test procedure is detailed in Appendix B2.

The idler shall meet these requirements at the completion of the test:

- a) the surface temperature of the idler shall not exceed 325°C,
- b) there shall be no visible flaming or visible glowing, and
- c) the material shall not drip molten material if the molten material could exceed 150°C.

3.5.2.4. Ignitability and flame propagation characteristics (finger burn test)

When tested in accordance with AS 1334.10, all non-metallic materials used in the construction of the idler, excluding bearing weather shields, shall meet the following requirements:

- a) the average duration of the visible flame shall not exceed 30 s and the average duration of the visible after glow shall not exceed 120 s, and
- b) the duration of the visible flame of any test piece shall not exceed 45 s and the duration of the visible afterglow of any test piece shall not exceed 180 s.

The persistence time of the flame shall include any flame from any molten material that drips from the test piece.

3.5.2.5. Oxygen index

Oxygen index tests shall be undertaken in accordance with, and meet the requirements of, Clause 6.2.3 of AS 4606:2012. Subsequent testing of the product must be within ± 3 points of that originally obtained.

The result shall not be less than 28%.

3.5.2.6. Electrical resistance

Non-metallic idlers shall have no more than 1 M Ω of electrical resistance between any two points at opposite ends of the idler shell, between the inside of the conveyor shell to the outside of the idler shell and between the idler shell and the idler shaft structure mounting points and ground (or any electrically connected earthing system).

Where the idler does not have a metallic shaft, or is used with a non-metallic conveyor structure, the idler shall be tested to ensure that there is no more than 1 M Ω of electrical resistance between any point on the structure to any point on the non-metallic idler, to prove effective grounding of static charges.

3.5.3. Production acceptance testing

Production acceptance testing shall be in accordance with the test methods for this product, as detailed in the QMS.

Where oxygen index testing is undertaken as part of the production acceptance testing detailed in the QMS, the results shall be within 3 percentage points of those originally obtained during type testing.

3.6. Non-metallic conveyor structure

3.6.1. Design

Conveyor belting rubbing on the non-metallic conveyor structure shall not initiate a fire due to friction between the non-metallic conveyor structure and the moving conveyor belting through the self-ignition or melting of the non-metallic material, or through excessive surface temperature.

The design of a bay of completely erected conveyor structure shall provide effective electrical connection at all joints so that any accumulated static charge from the conveyor belting can be effectively discharged to earth, without sparking occurring, when the structure with conveyor idlers and accessories is correctly assembled.

Non-metallic conveyor structure shall be designed to achieve the requirements identified in Clause 3.5 above, with additional requirements as detailed below.

The design shall provide for the retention of all properties during the life of the structure, including wear, abrasion and contamination of the surface.

3.6.2. Type testing

In addition to the type testing detailed in Clause 3.5.2 above, non-metallic conveyor structure shall be tested to comply with the requirements below.

3.6.2.1. Ignitability and maximum surface temperature

A test shall be carried out to determine whether a non-metallic conveyor structure can initiate a fire by friction between the structure and the moving conveyor belt due to excessive surface temperatures causing self-ignition or melting of the non-metallic material.

Refer to Appendix B2 for test procedure.

The structure shall meet these requirements at the completion of or during the test:

- a) the surface temperature of the idler shall not exceed 325°C,
- b) there shall be no visible flaming or visible glowing, and
- c) the material shall not drip molten material when the molten material could exceed 150°C.

3.6.2.2. Electrical resistance

At least one bay of conveyor structure shall be erected, complete with idlers. The electrical resistance between any point on the non-metallic conveyor structure or an idler roller to a proven effective earth shall not exceed 1 MΩ. The earthing point shall be nominated by the designer and may be a structure suspension point or the mounting feet of the structure legs.

3.6.3. Production acceptance testing

Production acceptance testing shall be in accordance with the test methods for this product, as detailed in the QMS.

3.7. Slider impact bars

3.7.1. Design

The design of slider impact bars shall comply with Clause 3.3 Conveyor accessories and with the requirements for toxicity of products of combustion as specified below.

3.7.2. Type testing

Slider impact bars shall be type tested and comply with performance requirements detailed below:

3.7.2.1. Toxicity of products of combustion

For small scale testing, each type of non-metallic material used in the conveyor idler construction shall be tested to and meet the requirements of Appendix C7 Toxicity testing.

When large scale testing is conducted, in addition to the small scale testing requirements, smoke obscuration should be measured, where possible. Smoke obscuration testing should be conducted in accordance with AS60695.6.1-2006 or an equivalent.

The results of the tests should be used in the risk analysis when assessing impacts of fire and the determination of control measures.

3.7.2.2. Ignitability and maximum surface temperature

A test shall be carried out to determine whether a slider impact bar can initiate a fire by friction between the slider impact bar and the moving conveyor belting due to excessive surface temperatures causing self-ignition or melting of the slider bar.

Refer to Appendix B2 for test procedure.

The slider impact bar shall meet these requirements at the completion of or during the test:

- a) the surface temperature of the idler shall not exceed 325°C,
- b) there shall be no visible flaming or visible glowing, and
- c) the material shall not drip molten material when the molten material could exceed 150°C.

3.7.2.3. Oxygen index

Oxygen index tests shall be undertaken in accordance with, and meet the requirements of, Clause 6.2.3 of AS 4606:2012. Subsequent testing of the product must be within ± 3 points of that originally obtained.

The result shall not be less than 28%.

3.7.2.4. Electrical resistance

The electrical surface resistance and the through resistance shall be measured across the conveyor belt contact surface and from the belt contact surface to the slider impact bar mounting surface in accordance with AS4606:2012 Clause 6.2.4.

3.7.3. Production acceptance testing

Production acceptance testing shall be in accordance with the test methods for this product, as detailed in the QMS.

Where oxygen index testing is undertaken as part of the production acceptance testing detailed in the QMS, the results shall be within 3 percentage points of those originally obtained during type testing.

4. Ventilation components and accessories

4.1. General

Non-metallic ventilation components and accessories being supplied for use in underground coal mines shall be designed to achieve the relevant performance criteria identified in this section of this document.

The design of each item shall be type tested to independently confirm the product has met the design specification.

For effective control of static electricity, ventilation components and accessories shall be designed with facilities that provide for the effective earthing of the product, when installed, to ensure that a static charge cannot accumulate on the product or the metallic or conductive attachments. No further earthing facilities need to be included in the product where the intended mounting method provides for effective dissipation of a charge.

Note: The intended mounting methods must be clearly detailed in product information provided by the manufacturer/supplier.

For FRAS products which do not pass the electrical resistance tests but are subjected to the spark incendivity test, all metallic or conductive attachments should be electrically bonded to the earthing facility.

4.2. Ventilation sheet (brattice)

All ventilation sheet shall be constructed of materials that meet the following requirements:

4.2.1. Design

Ventilation sheet shall be designed using materials that enable the requirements of fire resistance, oxygen index and electrical resistance detailed below to be achieved.

FRAS products which do not pass the electrical resistance tests, but have been subjected to spark incendivity tests, shall be provided with facilities that enable the effective earthing of any conductive attachments. All conductive attachments shall be electrically bonded to the earthing facility.

Brattice material shall also be designed to achieve the requirements of Clause 4.2.2.4 for air permeability.

4.2.2. Type testing

Ventilation sheet shall be tested in accordance with, and pass, the tests identified in the clauses below. Brattice shall also be tested in accordance with the requirements of Clause 4.2.2.4.

4.2.2.1. Fire resistance

Fire resistance testing shall be undertaken in accordance with the test below:

4.2.2.2. One kilowatt burner flame test

The one kilowatt burner flame test shall be conducted in accordance with the method detailed in Clause C1.1

The ventilation sheet shall meet the requirements specified in Clause C1.2.

4.2.2.3. Spirit lamp test

The spirit lamp test shall be conducted in accordance with the method in Clause C2.1.

The ventilation sheet shall meet the requirements specified in Clause C2.2

If during the spirit lamp test the material shrivels away such that the flame does not make contact with the material for the entire application time, then the ventilation sheeting may be retested in accordance with the "Follow-up" flame test as specified in Clause C3.

When tested in accordance with the method in Clause C3.1 the ventilation sheeting shall meet the requirements specified in Clause C3.2.

4.2.2.4. Oxygen index

The oxygen index of the ventilation sheet shall be determined in accordance with ISO 4589-2:2017 for characterisation of the material. Subsequent testing of the product must be within ± 3 points of that originally obtained. The use of commercial grade propane is acceptable.

4.2.2.5. Electrical resistance

The electrical resistance test shall be conducted in accordance with the method detailed in Clause C4.1.

The ventilation sheet shall meet the requirements specified in Clause C4.2.

Where the ventilation sheet does not meet the requirements of Clause C4.2, the spark incendivity test may be undertaken in accordance with the method in Clause C8.1.

Where subjected to the spark incendivity test, the ventilation sheet shall meet the requirements specified in Clause C8.2.

4.2.2.6. Air permeability

The brattice shall be tested in accordance with the method in Clause C6.1.

The brattice shall meet the requirements specified in Clause C6.2.

4.2.3. Production acceptance testing

Production acceptance testing shall be in accordance with the test methods for this product, as detailed in the QMS.

Where metallic or conductive attachments are fitted to the FRAS product and spark incendivity testing has been undertaken, the production acceptance testing detailed in the QMS shall include the measurement and recording of resistance for each of the metallic or conductive attachments to the earthing facility.

4.3. Non-metallic flexible ventilation ducting

4.3.1. Design

All non-metallic flexible ventilation ducting shall be designed and manufactured using materials and techniques that enable the requirements of fire resistance, oxygen index and electrical resistance detailed below to be achieved.

Flexible ventilation ducting shall have facilities that provide for the effective earthing of the ducting and any metallic or conductive attachments, when installed in accordance with the manufacturer's directions. Facilities shall be provided to ensure electrical conductivity between section of ducting when joined together.

4.3.2. Type testing

Non-metallic flexible ventilation ducting shall be tested in accordance with, and pass, the tests below.

Testing of the material used to manufacture the non-metallic flexible ventilation ducting, such as the sheeting material, may be tested separately by the manufacturer of that material.

If all of the materials used to manufacture the final product have already been type tested, then the completed product does not need to undergo further type testing.

4.3.2.1. Fire resistance

Fire resistance testing shall be undertaken in accordance with the test requirements detailed below:

4.3.2.2. One kilowatt burner flame test

The non-metallic flexible ventilation ducting shall be tested in accordance with the method in Clause C1.1.

The ducting shall meet the requirements specified in Clause C1.2.

4.3.2.3. Spirit lamp test

The non-metallic flexible ventilation ducting shall be tested in accordance with the method in Clause C2.1

The ducting shall meet the requirements specified in Clause C2.2.

If during the spirit lamp test the material shrivels away such that the flame does not make contact with the material for the entire application time, then the non-metallic flexible ducting shall be retested in accordance with the "Follow-up" flame test as specified in Clause C3.

When tested in accordance with the method in Clause C3.1 the non-metallic flexible ducting shall meet the requirements specified in Clause C3.2.

4.3.2.4. Oxygen index

The oxygen index of the non-metallic flexible ventilation ducting shall be determined in accordance with ISO 4589-2:2017 for characterisation of the material. Subsequent testing of the product must be within ± 3 points of that originally obtained. The use of commercial grade propane is acceptable.

4.3.2.5. Electrical resistance

In addition to testing of the material used for the manufacture of a section of flexible ducting, the electrical resistance testing shall include tests across at least one completed joint between sections of flexible ducting.

4.3.2.6. External surface

The electrical resistance test shall be conducted in accordance with the method detailed in Clause C4.1.

The ventilation ducting shall meet the requirements specified in Clause C4.2.

4.3.2.7. Internal surface

The internal surface of the non-metallic flexible ducting shall be tested in accordance with the method in AS 1180.13A:1983.

The electrical resistance of the internal surface of the finished ducting (with supporting spiral, coupling band and any accessories) shall not be greater than 1 MΩ/m.

The resistance of the internal surface measured across a fully assembled joint shall not be greater than 1 MΩ/m.

4.3.3. Production acceptance testing

Production acceptance testing shall be in accordance with the test methods for this product, as detailed in the QMS.

The production acceptance testing detailed in the QMS shall include assessment of joints between sections of ducting to ensure the joint allows charge to flow between sections without sparking.

Where metallic or conductive attachments are fitted to the FRAS product and spark incendivity testing has been undertaken, the production acceptance testing detailed in the QMS shall include the measurement and recording of resistance for each of the metallic or conductive attachments to the earthing facility.

4.4. Non-metallic rigid ventilation ducting

4.4.1. Design

All non-metallic rigid ventilation ducting shall be designed and manufactured using materials and techniques that enable the requirements of fire resistance, oxygen index and electrical resistance detailed below to be achieved.

4.4.2. Type testing

Non-metallic rigid ventilation ducting shall be tested in accordance with, and pass, the tests below.

All non-metallic rigid ventilation ducting shall be constructed of materials that meet the following requirements.

4.4.2.1. Fire resistance

Non-metallic rigid ventilation ducting material shall be tested in accordance with the method in AS 1180.10B:1982.

The average duration of flaming and glowing shall not exceed 30 seconds.

4.4.2.2. Oxygen index

The oxygen index of the non-metallic rigid ventilation ducting shall be determined in accordance with ISO 4589-2:2017 for characterisation of the material. Subsequent testing of the product must be within ± 3 points of that originally obtained. The use of commercial grade propane is acceptable.

4.4.2.3. Electrical resistance

4.4.2.4. Ducting material

Non-metallic rigid ventilation ducting material shall be tested in accordance with the method in AS 1180.13A:1983.

The electrical resistance of the ducting shall not be greater than 1 MΩ/m.

4.4.2.5. Joined ducting

The joined ducting shall be tested in accordance with the method in AS 1180.13A:1983.

The electrical resistance of the finished ducting, across a fully assembled joint, shall not be greater than 1 MΩ/m.

4.4.3. Production acceptance testing

Production acceptance testing shall be in accordance with the test methods for this product, as detailed in the QMS.

The production acceptance testing detailed in the QMS shall include assessment of joints between sections of ducting to ensure the joint allows charge to flow between sections without sparking.

Where metallic or conductive attachments are fitted to the FRAS product and spark incendivity testing has been undertaken, the production acceptance testing detailed in the QMS shall include the measurement and recording of resistance for each of the metallic or conductive attachments to the earthing facility.

4.5. Joining bands for non-metallic ventilation ducting

4.5.1. Design

Joining bands for non-metallic ventilation ducting shall be designed and manufactured using materials and techniques that enable the requirements of fire resistance, oxygen index and electrical resistance detailed below to be achieved.

4.5.2. Type testing

The joining bands shall be tested in accordance with, and pass, the tests identified below.

4.5.2.1. Fire resistance

The joining bands for non-metallic ventilation ducting shall be tested in accordance with the method in AS 1180.10B:1982.

With a flame application time of 20 seconds only, the average duration of flaming and glowing shall not exceed 30s.

4.5.2.2. Oxygen index

The oxygen index of the joining bands for non-metallic ventilation ducting shall be determined in accordance with ISO 4589-2:2017 for characterisation of the material. Subsequent testing of the product must be within ± 3 points of that originally obtained. The use of commercial grade propane is acceptable.

4.5.2.3. Electrical resistance

Where the design of the joining band permits the band to be turned inside out (i.e. there is no difference between the inner side and the outer side) then the tests for internal surface shall be applied to both sides of the joining band. The external surface test does not need to be undertaken in this situation.

4.5.2.4. External surface

The Electrical resistance test shall be conducted in accordance with the method detailed in Clause C4.1.

The joining bands shall meet the requirements specified in Clause C4.2.

4.5.2.5. Internal surface

The internal surface of the joining band shall be tested in accordance with the method in AS 1180.13A:1983.

The electrical resistance of the internal surface of the joining band shall not be greater than 1 MΩ/m.

4.5.3. Production acceptance testing

Production acceptance testing shall be in accordance with the test methods for this product, as detailed in the QMS.

The production acceptance testing detailed in the QMS shall include assessment of joints between sections of ducting to ensure the sealing band allows charge to flow between ducting sections without sparking.

5. Other defined applications

5.1. Air / water hose

5.1.1. Design

General purpose air and water hoses used in underground coal mines shall be designed to achieve the performance requirements for fire resistance, oxygen index and electrical resistance detailed below.

5.1.2. Type testing

Air and water hoses used in underground coal mines shall be tested in accordance with and meet the requirements below.

5.1.2.1. Fire resistance

When tested in accordance with AS 1180.10B:1982, the average duration of flaming and glowing shall not exceed 30 s.

5.1.2.2. Oxygen index

The oxygen index of air and water hose shall be determined in accordance with ISO 4589-2:2017 for characterisation of the material. Subsequent testing of the product must be within ± 3 points of that originally obtained. The use of commercial grade propane is acceptable.

5.1.2.3. Electrical resistance

This test shall be undertaken on a metre length of hose.

When tested in accordance with AS 1180.13A:1983, the electrical resistance shall not be greater than 1 M Ω /m.

5.1.3. Production acceptance testing

Production acceptance testing shall be in accordance with the test methods for this product, as detailed in the QMS.

Where oxygen index testing is detailed in the QMS as a part of production acceptance testing, results shall be within 3 percentage points of that obtained during type testing.

Production acceptance testing detailed in the QMS shall include assessment of joints between sections of hose to ensure the joint allows charge to flow between sections without sparking.

5.2. Hydraulic hose

5.2.1. Design

Hydraulic hoses used in underground coal mines shall be designed to achieve the performance requirements for fire resistance as detailed below.

The hydraulic hose shall have antistatic properties for the outer cover of the hose.

5.2.2. Type testing

Hydraulic hoses used in underground coal mines shall be tested in accordance with and meet the requirements of the clauses below.

5.2.2.1. Fire resistance

Hydraulic hoses shall be tested in accordance with ISO 8030:2014.

The hoses shall meet the requirements of Clause 6.3 of ISO 6805:2020.

5.2.2.2. Electrical resistance

Hydraulic hoses shall be tested in accordance with ISO 8031:2020 clauses 4.5 and 4.6.

The hoses shall meet the requirements of Clause 6.2 of ISO 6805:2020.

5.2.3. Production acceptance testing

Production acceptance testing shall be in accordance with the test methods for this product, as detailed in the QMS.

The production acceptance testing detailed in the QMS shall require the testing to be undertaken without fittings, as per type tests.

5.3. Grid mesh

5.3.1. Design

Non-metallic grid mesh used in underground coal mines shall be designed to achieve the performance requirements for fire resistance, oxygen index and electrical resistance detailed below.

5.3.2. Type testing

Non-metallic grid mesh used in underground coal mines shall be type tested in accordance with, and meet the requirements below.

5.3.2.1. Fire resistance

5.3.2.2. One kilowatt burner flame test

The non-metallic grid mesh shall be tested in accordance with the method in Clause C1.1.

The mesh shall meet the requirements specified in Clause C1.2.

5.3.2.3. Spirit lamp test

The non-metallic grid mesh shall be tested in accordance with the method in Clause C2.1

The mesh shall meet the requirements specified in Clause C2.2.

If during the spirit lamp test the material shrivels away such that the flame does not make contact with the material for the entire application time, then the grid mesh may be retested in accordance with the "Follow – Up" Flame Test as specified in Clause C3. When tested in accordance with the method in Clause C3.1 the ventilation sheeting shall meet the requirements specified in Clause C3.2.

5.3.2.4. Oxygen index

The oxygen index of grid mesh shall be determined in accordance with ISO 4589-2:2017 for characterisation of the material. Subsequent testing of the product must be within ± 3 points of that originally obtained. The use of commercial grade propane is acceptable.

5.3.2.5. Electrical resistance

The non-metallic grid mesh shall be tested in accordance with the method in Clause C4.1.

The grid mesh shall meet the requirements specified in Clause C4.2.

5.3.3. Production acceptance testing

Production acceptance testing shall be in accordance with the test methods for this product, as detailed in the QMS.

Where oxygen index testing is undertaken as part of the production acceptance testing detailed in the QMS, the results shall be within 3 percentage points of those originally obtained during type testing.

5.4. V-belts and wedge belts

5.4.1. Design

Any V-belts or wedge belts used in underground coal mines shall be designed to achieve the performance requirements for fire resistance, oxygen index and electrical resistance detailed below.

5.4.2. Type testing

V-belts or wedge belts used in underground coal mines shall be tested in accordance with and meet the requirements below.

5.4.2.1. Fire resistance

V-belts or wedge belts shall be tested in accordance with AS 2784:2002 Appendix E.

The belts shall meet the requirements of Clause 2.9 of AS 2784:2002.

5.4.2.2. Oxygen index

The oxygen index of v-belts or wedge belts shall be determined in accordance with ISO 4589-2:2017 for characterisation of the material. Subsequent testing of the product must be within ± 3 points of that originally obtained. The use of commercial grade propane is acceptable.

5.4.2.3. Electrical resistance

V-belts or wedge belts shall be tested in accordance with AS 2784:2002 Appendix D.

The belts shall meet the requirements of Clause 2.8 of AS 2784:2002.

5.4.3. Production acceptance testing

Production acceptance testing shall be in accordance with the test methods for this product, as detailed in the QMS.

Where oxygen index testing is undertaken as part of the production acceptance testing detailed in the QMS, the results shall be within 3 percentage points of those originally obtained during type testing.

5.5. Rib/roof bolts

5.5.1. Design

Non-metallic rib/roof bolts and supports incorporating fibreglass dowels and plastic rods, and any non-metallic holding (fastening) nuts shall be designed using materials that meet the requirements of fire resistance, oxygen index and electrical resistance detailed below.

No external conductive coating or external metallic conductor shall be permitted.

5.5.2. Type testing

Non-metallic rib/roof bolts and supports incorporating fibreglass dowels and plastic rods, and any non-metallic holding (fastening) nuts shall be tested as a complete assembly in accordance with, and pass, the tests identified below.

5.5.2.1. Fire resistance

Non-metallic rib/roof bolts shall be tested in accordance with AS 1180.10B:1982.

The average duration of flaming and glowing times combined shall not exceed 30 seconds.

5.5.2.2. Oxygen index

The oxygen index of roof/rib bolts shall be determined in accordance with ISO 4589-2:2017 for characterisation of the material. Subsequent testing of the product must be within ± 3 points of that originally obtained. The use of commercial grade propane is acceptable.

5.5.2.3. Electrical resistance

Non-metallic rib/roof bolts shall be tested in accordance with the method in Clause C5.1

The rib/roof bolts shall meet the requirements of Clause C5.2.

5.5.3. Production acceptance testing

Production acceptance testing shall be in accordance with the test methods for this product, as detailed in the QMS.

Where oxygen index testing is undertaken as part of the production acceptance testing detailed in the QMS, the results shall be within 3 percentage points of those originally obtained during type testing.

5.6. Flexible intermediate bulk containers (FIBC)

Stone dust bags are included as flexible intermediate bulk containers (FIBC).

5.6.1. Design

Flexible intermediate bulk containers (FIBC) used in underground coal mines shall be designed to achieve the performance requirements for Fire resistance and electrical resistance detailed below.

5.6.2. Type testing

The FIBC used in underground coal mines shall be tested in accordance with and meet the requirements below.

5.6.2.1. Fire resistance

5.6.2.2. One kilowatt burner flame test

The FIBC shall be tested in accordance with the method in Clause C1.1.

The FIBC shall meet the requirements specified in Clause C1.2.

5.6.2.3. Spirit lamp test

The FIBC shall be tested in accordance with the method in Clause C2.1.

The FIBC shall meet the requirements specified in Clause C2.2.

If during the spirit lamp test the material shrivels away such that the flame does not make contact with the material for the entire application time, then the FIBC may be retested in accordance with the "Follow-up" flame test as specified in Clause C3. When tested in accordance with the method in Clause C3.1 the FIBC shall meet the requirements specified in Clause C3.2.

5.6.2.4. Electrical resistance

When tested in accordance with the method in Clause C4.1, the FIBC shall meet the requirements in Clause C4.2.

Alternatively, the FIBC may be tested to and meet the requirements in IEC 61340-4-4.

5.6.3. Production acceptance testing

Production acceptance testing shall be in accordance with the test methods for this product, as detailed in the QMS.

5.7. Bags used for explosion barriers (bat bags)

5.7.1. Design

Bat bags used in underground coal mines shall be designed to achieve the performance requirements for electrical resistance detailed below.

5.7.2. Type testing

Bat bags used in underground coal mines shall be tested in accordance with and meet the requirements below.

5.7.2.1. Electrical resistance

The electrical resistance test shall be conducted in accordance with the method detailed in Clause C4.1.

The bat bag shall meet the requirements specified in Clause C4.2.

Where the bat bag does not meet the requirements of Clause C4.2, the spark incendivity test may be undertaken in accordance with the method in Clause C8.1.

The bat bag shall meet the requirements specified in Clause C8.2.

5.7.3. Production acceptance testing

Production acceptance testing shall be in accordance with the test methods for this product, as detailed in the QMS.

5.8. Non-metallic pipe

5.8.1. Design

Any non-metallic pipe used in underground coal mines shall be designed to achieve the performance requirements for fire resistance, oxygen index, electrical resistance and toxicity detailed below.

Where used as part of a gas drainage system, the pipe shall be designed to be anti-static to the test values in 5.8.2.3 for the full thickness of the pipe. That is, coatings shall not be permitted in this application.

Where an external conductive coating is used, the designer of the pipe and coating must ensure that the performance of the coated pipe is maintained if the coating was to be physically damaged (gouged, scraped or scratched) or if the pipe becomes heat affected. Where susceptible to damage, the impact on FRAS properties must be risk assessed by the designer/manufacturer/supplier and the end user. Any limitations on use and discard criteria related to coating damage must be communicated to the end user.

The pipe shall be designed to ensure effective grounding to earth can be achieved when the pipe is installed. Joints between sections of pipe shall be designed so that charge may flow across the joint without risk of sparking occurring.

5.8.2. Type testing

The non-metallic pipe used in underground coal mines shall be tested in accordance with and meet the requirements below.

5.8.2.1. Fire resistance

Non-metallic pipe shall be tested in accordance with the method in AS 1180.10B:1982.

The average duration of flaming and glowing combined shall not exceed 30 seconds.

5.8.2.2. Oxygen index

The oxygen index of non-metallic pipe shall be determined in accordance with ISO 4589-2:2017 for characterisation of the material. Subsequent testing of the product must be within ± 3 points of that originally obtained. The use of commercial grade propane is acceptable.

5.8.2.3. Electrical resistance

The electrical resistance test shall be undertaken in accordance with the method in Clause C5.1

The electrical resistance shall meet the requirements of Clause C5.2.

The electrical resistance test shall also be undertaken on a section of pipe that includes a joint made in accordance with the manufacturer's recommendations and shall be tested in accordance with the method in Clause C5.1 and shall meet the requirements of Clause C5.2.

Where antistatic properties of a pipe are depending on the integrity of a coating, the coating shall be removed to the maximum extent identified by the manufacturer in their documentation as safe to remain in service and the pipe subjected to a spark incendivity test as per Clause C8.

Where a non-metallic pipe is intended to be used as part of a gas drainage system, the electrical resistance of both the inner and the outer surfaces must not be greater than 1 M Ω /m. Through resistance, from inner to outer of the pipe, must not be greater than 1 M Ω /m.

5.8.2.4. Toxicity

The non-metallic pipe shall be tested in accordance with the requirements of Clause C7.1.

The pipe shall meet the requirements of Clause C7.2 Toxicity testing.

5.8.3. Production acceptance testing

Production acceptance testing shall be in accordance with the test methods for this product, as detailed in the QMS.

Where oxygen index testing is undertaken as part of the production acceptance testing detailed in the QMS, the results shall be within 3 percentage points of those originally obtained during type testing.

Production acceptance testing detailed in the QMS shall include assessment of joints between sections of pipe to ensure the joint allows charge to flow between sections without sparking.

6. Non-defined applications

6.1. Risk management

All other non-metallic materials (not specified above in earlier sections of this document) intended for use in underground parts of a coal mine shall be assessed for the risk of:

- a) combustibility,
- b) static electric discharge, and
- c) toxicity of products of combustion in the intended operating environment.

NOTE: This is not an exhaustive list; there may be other risks present, e.g. excessive temperature from surface friction.

Where there is a risk, the risk assessment shall be supplied to the end user.

Where the risk assessment identifies the need for fire resistant, antistatic or limited toxicity properties then the material shall have (as far as reasonably practicable) the relevant properties as specified below or as specified in a relevant recognised standard for the material's application.

NOTE: Where the following tests are not applicable to the product or application, alternative testing in accordance with Clause 2.2.5. Alternative Equivalent Tests shall be identified and undertaken on the product.

6.2. Design

Non-metallic materials used in underground coal mines shall be designed to achieve the performance requirements for fire resistance, oxygen index, electrical resistance and toxicity below.

Where a non-metallic material is likely to hold an electrostatic charge such as large surface areas, moving components, near or touching moving components, or in the path of an air-stream, particularly when containing entrained solid or liquid particles, the material shall have anti-static properties suitable for the intended application.

The non-metallic materials shall be designed with facilities that provide an effective connection to earth of any metallic or conductive fitting connected to the material.

FRAS products which do not pass the electrical resistance tests, but have been subjected to spark incendivity tests, shall be provided with facilities that enable the effective earthing of any conductive attachments. All conductive attachments shall be electrically bonded to the earthing facility.

6.3. Type testing

The non-metallic material (not specified above in earlier sections of this document) used in underground coal mines shall be tested in accordance with, and meet the requirements of, the clauses below.

6.3.1. Fire resistance

When tested in accordance with AS 1334.10, the test pieces shall meet the requirement of Clause 6.2.2 of AS 4606:2012.

If no more than two individual sample tests fail due to re-ignition from molten material hitting the gauze under the burner, the test may be redone on a full set of samples by moving the gauze from 6 millimetres to 12 millimetres, provided the test facility has sufficient samples from the same batch. This modified testing shall be noted on the test report.

NOTE: For polymers that drip under this test, the burner may be rotated 45 degrees about the longitudinal axis of the finger in order to prevent molten material falling into the burner.

For non-rubber products such as polyurethane, as an alternative test method to AS1334.10 the following tests may be carried out:

- a) IEC60695.11-10:2013. To be considered FRAS, the material must meet the requirements of classification V-0 as detailed in section 9.4.

AND

- b) IEC60695.11-20:2015. To be considered FRAS, the material must meet the requirements of classification 5VB as detailed in section 8.4.

Irrespective of what is stated in IEC60695, the result only applies for the colour and unique product tested, that is each colour or variation to material blend is required to be tested and meet the above criteria to be considered FRAS.

6.3.1.1. Ignitability and flame propagation characteristics (finger burn test)

When tested in accordance with AS 1334.10:1994 the maximum allowable duration of the visible flame shall not exceed 10 seconds for the average of all tests and 15 seconds for any single test.

6.3.1.2. Combustion propagation characteristics

As an alternative to the finger burn test, for hose or hose type products the average duration of the flame and glowing combined should not exceed 30 seconds when tested in accordance with AS 1180.10B:1982.

6.3.2. Oxygen index

When tested in accordance with ISO 4589-2:2017, the result shall not be less than 28%. The use of commercial grade propane is acceptable.

6.3.3. Antistatic properties (electrical resistance)

Verification of anti-static properties shall be in accordance with the following sub-Clauses or alternatively a recognised standard for the material's intended application.

6.3.3.1. General applications

For flat surfaces, when tested in accordance with the method in Clause C4.1, the product shall meet the requirements of Clause C4.2.

For rods, the material shall be tested in accordance with the method in Clause C5.1 and shall meet the requirements of Clause C5.2.

6.3.3.2. Higher risk applications

Applications exposed to high air velocities or to high levels of liquid or solid particles requiring a lower level of electrical resistance shall meet the requirements of Clause 2.2 of AS 2660:1991.

6.3.3.3. Discharge between two surfaces

Where the normal electrical discharge path is between two surfaces, the average of two resistance measurements shall not exceed $300 \text{ M}\Omega$ when tested to Clause 9.2 or 9.3 of ISO 2878:2017.

6.3.3.4. Spark incendivity

Where the application does not meet the requirements of Clause C4.2 or Clause C5.2 as applicable, the spark incendivity test may be undertaken in accordance with the method in Clause C8.1.

Where subjected to the spark incendivity test, the application, with all highly conductive attachments and fittings shall meet the requirements specified in Clause C8.2.

6.3.4. Toxicity of products of combustion

Where there is a risk that the products of combustion of the material, in the event of a fire, is likely to affect the toxicity of the mine environment to a point above safe exposure levels to people, then the requirements of Appendix C7 Toxicity testing shall be applied.

NOTE: Toxicity testing is not required where it can be reasonably demonstrated that there is no fire risk or risk from the products of combustion.

6.3.5. Production acceptance testing

Production acceptance testing shall be in accordance with the test methods for this product, as detailed in the QMS.

Where oxygen index testing is undertaken as part of the production acceptance testing detailed in the QMS, the results shall be within 3 percentage points of those originally obtained during type testing.

Appendix A - Associated documents

1. The control of undesirable static electricity

AS 1180.10B:1982	Methods of test for hose made from elastomeric materials - Determination of combustion propagation characteristics of a horizontally oriented specimen of hose using surface ignition
AS 1180.13A:1983	Methods of test for hose made from elastomeric materials - Determination of electrical resistance of hose and hose components
AS 1334.9:1982	Methods of testing conveyor and elevator belting - Determination of electrical
AS 1334.10:1994	Methods of testing conveyor and elevator belting - Determination of ignitability
AS 1334.11:1988	Methods of testing conveyor and elevator belting - Determination of ignitability
AS 1334.12:1996	Methods of testing conveyor and elevator belting - Determination of combustion
AS 2660:1991	Hose and hose assemblies - Air/water - For underground coal mines
AS 2784 :2002	Endless wedge belt and V-belt drives
AS 4606:2012	Grade S fire resistant and antistatic requirements for conveyor belting and conveyor accessories
AS/NZS ISO 9001:2016	Quality management systems - Requirements

2. International Standards (ISO and IEC)

ISO 2878:2017	Rubber - Antistatic and conductive products - Determination of electrical resistance
ISO 4589-2:2017	Plastics - Determination of burning behaviour by oxygen index – Part 2: Ambient temperature test
ISO 6805:1994	Rubber hoses and hose assemblies for underground mining - Wire-reinforced hydraulic types for coal mining - Specification
ISO 8030:2014	Rubber and plastics hoses - Method of test for flammability
ISO 8031:2009	Rubber and plastics hoses and hose assemblies - Determination of electrical resistance and conductivity
IEC 61340-4-4 Ed 3.0:2018	Electrostatics Part 4-4: Standard test methods for specific applications- Electrostatic classification of flexible intermediate bulk containers (FIBC)
IEC 60695-11-2 Ed 3.0:2017	Fire Hazard Testing Part 11-2: Test flames – 1 kW nominal premixed flame- Apparatus, confirmatory test arrangement and guidance.

3. National Coal Board Standards United Kingdom (NCB)

NCB 245:1985	Fire and electrical resistance properties of supported and unsupported sheeting, issued by the National Coal Board of the United Kingdom
NCB 441:1964	Brattice sheeting made from textile supported plastics, issued by the National Coal Board of the United Kingdom
RD/NMMB (84) 3	Anti-static requirement for rigid plastics pipe for underground use, issued by the National Coal Board of the United Kingdom

4. Other publications

AFAP-3 Ed. 3 2010	NATO Reaction-to-fire-tests for Materials – Toxicity of Fire Effluents
-------------------	--

Appendix B – Non-metallic conveyor idler tests

Flame propagation of non-metallic and lagged conveyor idlers test

1. Method

1.1.1. Scope

This test protocol sets out a method for testing the flame propagation characteristics of non-metallic conveyor idlers and of lagged conveyor idlers. The purpose of the test is to demonstrate that the use of the non-metallic materials does not increase the fire risk above what is present if metallic idlers alone are to be used.

1.1.2. Principle

Non-metallic and lagged idlers are installed on a trestle and placed in a test gallery that is subjected to a controlled airflow. A piece of conveyor belting is placed on top of the idlers and the idler/belting assembly is exposed to a flame (from underneath) from a propane burner for a specified time. After the burner is removed the idler/belting assembly is left on the trestle until all visible flame and glow have disappeared and a measurement of the undamaged length is made.

1.1.3. Application to fire hazard

These test results on their own are not sufficient to indicate the fire hazard of the idler/conveyor combination under actual fire conditions and consequently should not be applied to the assessment of fire hazard without taking into account additional supportive information.

1.1.4. Apparatus

The apparatus is the same as used in AS 1334.12-1996, with the following exceptions:

The trestle shall be designed in such a way as to allow the installation of the non-metallic conveyor idlers being tested. The idlers shall be mounted on the trestle so that the lowest point of the idler surface is 350 millimetres from the floor of the test gallery. The distance from the underside of the idler to the burner is to be 100 millimetres. NOTE: This is normally 130 millimetres.

There is to be two idlers end to end in the centre so there is a gap between each idler as would normally occur in conventional structure. NOTE: This is to simulate a potential tracking path.

Longitudinal location of the idlers is given in Figure 1.

Figure 1. Idler flame propagation test apparatus

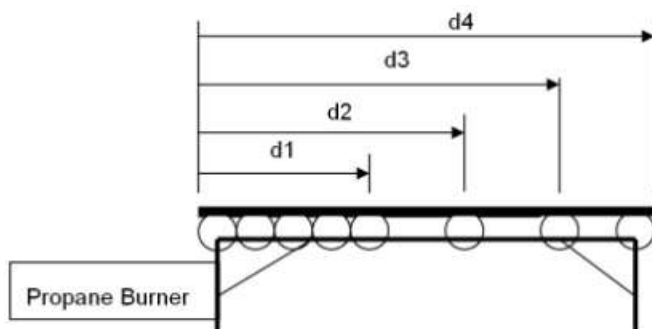

$d1 = 950 \text{ to } 1050 \text{ mm}$ (skin to skin, measured to idler centre)

$d2 = (d1 + d3) \div 2$ (measured to idler centre)

$d3 = 1750 \text{ mm}$ (measured to idler centre)

$d4 = 2000$ (total length to outside diameter)

1.1.5. Test pieces

1.1.5.1. Samples

Full width idler samples shall be supplied for testing. A 4-metre length (minimum) of conveyor belting shall also be supplied (width 1050 to 1200 millimetres).

1.1.5.2. Conditioning

Samples shall be conditioned at atmospheric temperature and humidity for 24 hours prior to testing.

1.1.6. Procedure

The test procedure shall be the same as given in AS 1334.12:1996, with the following exceptions:

- a) The sample of conveyor belting shall be cut into three separate 2-metre long test pieces. The belt shall not be of steel cord construction.
- b) A test to AS 1334.12:1996 shall be performed on one of the test pieces to determine its propagation characteristics without the influence of the idlers. Steel idlers shall be used. The undamaged length on the underside of this test piece shall be a maximum of 500 millimetres.
- c) A second test shall then be performed with the conveyor belting resting on top of the non-metallic/lagged idlers skin to skin as per the figure above.
- d) A third test shall be performed with the idlers set at approximately 300 millimetres between centres.

NOTE: Other tests may be required, subject to the results of these tests.

1.1.7. Report

The report shall include all results and the test procedure.

1.2. Requirements

The idler at the 1750 millimetres mark shall not be damaged. If it is damaged the test shall be repeated so the edge of the idler is set at 1750 millimetres, instead of the centre of the idler.

When tested to this test method, the conveyor belt shall have an undamaged length greater than 250 millimetres.

2. Ignitability and surface temperature - component subject to friction test

2.1. Method

2.1.1. Scope

This example test protocol sets out a method for testing the ignition and wear properties of a stationary component (such as a seized non-metallic conveyor idler, a lagged metallic idler or a slider bar) subjected to friction from a moving conveyor belt.

2.1.2. Principle

A friction test apparatus may be used to simulate the scenario of a stationary component with conveyor belting rubbing on it under a normal loading of coal. A stationary component is made to contact an endless loop of conveyor belting driven around a set of pulleys and idlers with a specified minimum force until:

- a) the component breaks or deforms in such a way as to remove the fire hazard due to friction,
- b) the maximum allowable temperature is exceeded,

- c) the component ignites, or
- d) the specified time elapses.

2.1.3. Test criteria

A stationary component shall be tested under the following conditions:

- a) Conveyor belting shall run continuously over the stationary component at a speed of not less than the designed belt speed or 3.0 metres/second, whichever is the greater.
- b) The tested component shall be loaded with a normal (perpendicular) load of at least 125% of the maximum design dynamic load applied to the idler from the conveyor.
- c) At least one metal belt clip joint shall be included in the conveyor belt.
- d) When conducting testing, all conveyor belt types used with the tested component should be considered and a range of combinations tested and assessed.
- e) The conveyor belting shall be run without water sprays or product during the test.
- f) The conveyor shall run continuously over a period of at least 2 hours past the point where temperature stabilises or for a period of 8 hours, whichever is the lesser.

2.1.4. Application to fire hazard

These test results on their own are not sufficient to indicate the fire hazard of the stationary component under actual fire conditions and consequently should not be applied to the assessment of fire hazard without taking into account additional supportive information.

2.1.5. Apparatus

The following is required:

- a) A dynamic test rig consisting of an endless loop of belting being driven around a set of pulleys and idlers at the greater of design speed or 3.0 metres/second. The component being tested is installed at the end of a hinged arm over the belting, loaded to simulate a typical full conveyor load (see Figure 2). The arm shall be designed in such a way as to allow it to be periodically raised during a test to facilitate temperature measurement of the contacting surface of the component.
- b) A suitable non-invasive temperature measuring device, and
- c) a suitable timing device.

Figure 2 Idler friction test apparatus

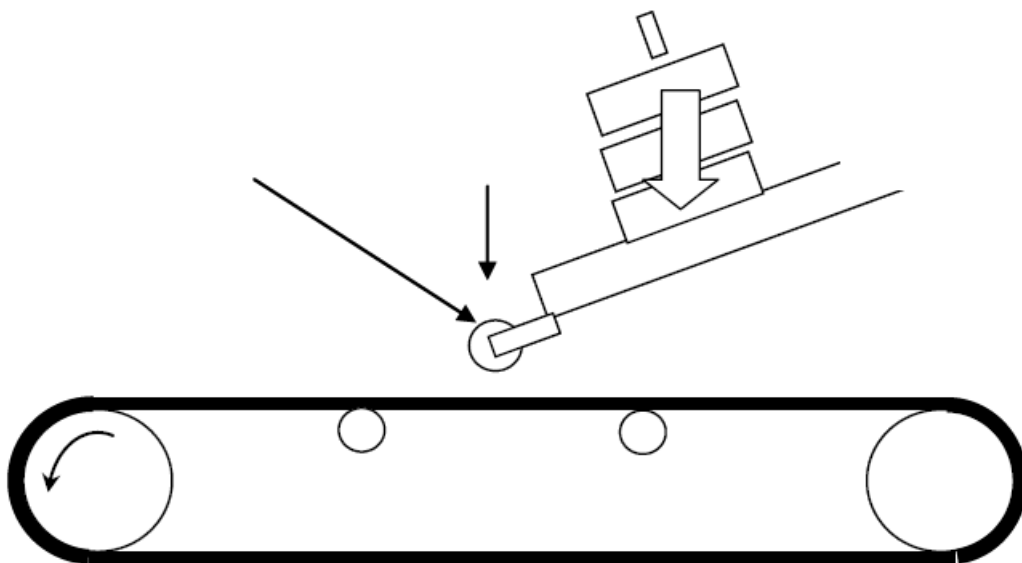

2.1.6. Test pieces

2.1.6.1. Samples

Full width samples shall be supplied for testing. Where the component is constructed from more than one layer of non-metallic compound, one test sample per layer shall be supplied.

2.1.6.2. Conditioning

Samples shall be conditioned at atmospheric temperature and humidity for 24 hours prior to testing.

2.1.7. Procedure

- a) Install the idler on the hinged arm. The test mass on the arm shall ensure the idler contacts the belt with a force of 125% of the dynamic belt loading throughout the test.
- b) Measure the initial temperature of the surface of the idler to be in contact with the conveyor belt.
- c) Start the dynamic rig and set a conveyor speed of 3.0 (+0.5/-0) metres/second. Lower the hinged arm so that the test idler contacts the conveyor under full test load.
- d) Raise the arm and record the temperature of the contacting surface of the component at 15-minute intervals.
- e) Record the time at which breakage or other deformation that removes the fire hazard of the component occurs (if any).
- f) Record the time at which a visible flame is observed (if any).
- g) Record the time at which a temperature $>325^{\circ}\text{C}$ at the contacting surface of the idler is recorded (if any).
- h) Stop the test after 8 hours of continuous running.

2.1.8. Report

The report shall include all results and the test procedure.

Appendix C – Test methods

1. One kilowatt burner flame test

1.1. Method

This method has been adapted from the National Coal Board Specification NCB 245:1985 Fire and electrical resistance properties of supported and unsupported sheeting, Appendix 2 – 1 Kilowatt spirit burner flame test procedure.

1.1.1. Test pieces

1.1.1.1. Selection of test pieces

Samples of not less than 3 metres² shall be selected for test from material in sheet or roll form.

NOTE: Samples can be cut from the same 3 metres² sheet as supplied for tests C3 Spirit lamp test and C4 "Follow-up" flame test.

Six test pieces, 50 millimetres wide × 360 millimetres long shall be cut cleanly from the sample. Three test pieces shall be cut parallel to the length of the sheeting and three at right-angles to it. The test pieces shall be cut from places widely spaced from each other so that they are representative of the whole area of the sample of sheeting.

1.1.1.2. Conditioning

The test pieces shall be conditioned by free suspension at normal room temperature and humidity with both sides freely exposed to the atmosphere for at least 12 hours.

1.1.2. Test apparatus

1.1.2.1. Spirit burner

A spirit burner complying with the requirements of BS 5865 'Specification for construction and burner for small-scale laboratory tests'. The supply of fuel be from a reservoir having a graduated arm.

The burner shall be supplied with IMS 95 methylated spirit at a rate of 2.55 ± 0.15 millilitres/minute. The fuel level reservoir shall be maintained within the range 760 ± 20 millimetres above the base of the burner.

1.1.2.2. Alternative burner and fuel

As an alternative to the above, a 1 kilowatt burner that meets the requirements of IEC 60695-11-2 may be used.

1.1.2.3. Cabinet

The test shall be carried out in a cabinet generally to the design and dimensions in Figure 3 Schematic diagram of cabinet. The inside of the cabinet shall be black.

A fume hood, with an extraction fan, may be positioned above the cabinet; the fan may be run during the test provided that it does not induce air movement through the cabinet additional to that required for the operation of the burner. Where this condition is not satisfied the fan shall be switched off during the test.

If required, additional close-fitting holes may be made in the cabinet to permit the entry of a remote handling device for the burner and the fuel pipe.

1.1.2.4. Stand for flame test

The purpose of the stand, which is shown in Figure 4 Experimental set up for the spirit burner test, is to hold both the test piece and the spirit burner in the required positions for carrying out the test.

The stand consists of a fabricated light steel frame and the test piece is suspended from the top crossbar of the stand by means of a spring-clip. The lower corner of the test piece is slipped into a simple fork formed by a longitudinal saw cut in the end of a steel strip. The steel strip shall be not larger than 10 millimetres wide and 3 millimetres thick.

The fork serves to hold the test piece steady during the test and shall be fixed to the stand such that the distance from the bottom edge of the fork to the bottom end of the test piece is 12 millimetres and the distance from the end of the fork to the side edge of the test piece is 25 millimetres.

A rotating bracket or similar device is attached to the side of the stand opposite the fork with arrangements for clamping the burner at an angle of 45° to the vertical. By this means the burner may be moved so that the flame either plays on the test piece or is well clear of it.

A small metal tray is fixed to the stand approximately 15 millimetres below the bottom edge of the test piece when in the test position. This tray serves to catch any portion of the test piece which may fall and allows it to continue burning. A marker is stretched horizontally across the stand in front of the test piece. This consists of a length of 20 SWG wire and is set 280 millimetres above the bottom edge of the test piece.

Alternative stand and burner support designs are acceptable provided that they are dimensionally equivalent.

1.1.3. Procedure

- a) Tests shall be carried out in the test cabinet in subdued light.
- b) Light the burner and check for correct operation.
- c) The position of the burner in its clamp shall be adjusted so that, when in the test position, the centre of the burner mouth is 50 millimetres below and 50 millimetres to one side of the nearer lower corner of the test piece with the in the plane of the test piece.
- d) Each test piece shall be in the burner flame for 20 seconds and the burner and flame shall then be swung clear of the test piece.
- e) The behaviour of each test piece shall be observed from the time the flame is applied until at least 30 seconds after any flame or glow on the test piece is extinguished.

1.1.4. Expression of results

The following results shall be stated in the test report:

- a) the time for all visible flame and glow to disappear for each of the six individual test pieces, and
- b) the mean time for all visible flame and glow to disappear for the six test pieces.

Figure 3 Schematic diagram of cabinet

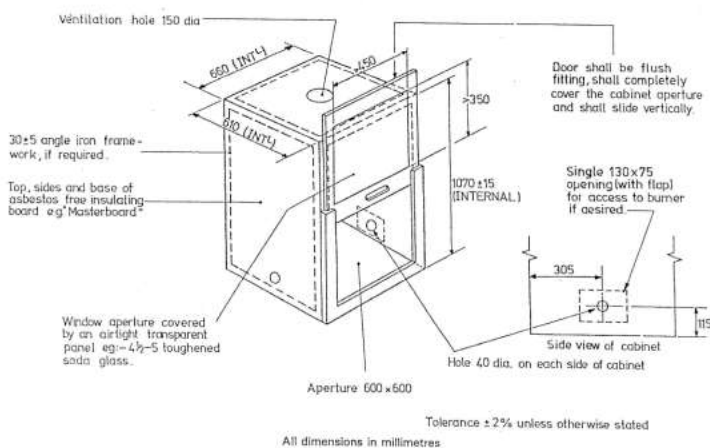
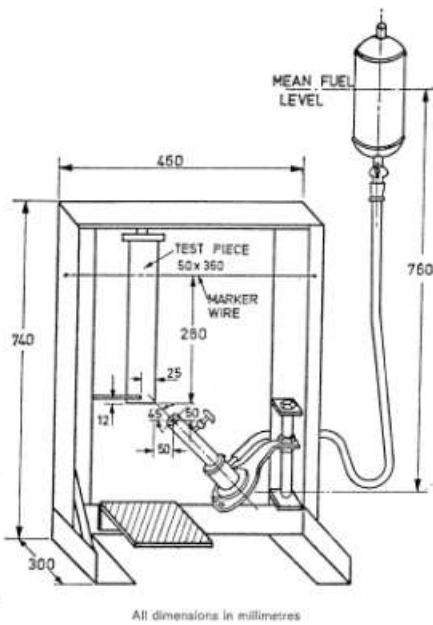

Figure 4 Typical experimental set up for the spirit burner test



1.2. Requirements

The material shall fail the test if any of the following occur:

- a) If at any time:
 - i. a flame on two or more test pieces extends above the marker wire, or
 - ii. a glow on two or more test pieces extends above the marker wire.

If on only one test piece a flame or glow extends above the marker wire, then a further six test pieces shall be prepared and tested. In this circumstance the material shall fail the test if flame or glow extends above the marker wire from any single test piece.

- b) If after the burner flame has been removed:
 - i. the mean persistence time of the flame of each of the six test pieces exceeds 3 seconds, or if the persistence time of the flame on any one test piece exceeds 10 seconds
 - ii. the mean persistence time of the glow of each of the six test pieces exceeds 10 seconds or if the persistence time of the glow on any one test piece exceeds 30 seconds.

Glow time shall be measured from the instant of removal of the burner flame from the test piece.

The requirements of all tests above refer to the suspended test pieces and any portions that may have fallen from the test pieces.

2. Spirit lamp test

2.1. Method

This method has been adapted from the Appendices' of the National Coal Board Specification NCB 245:1985 Fire and electrical resistance properties of supported and unsupported sheeting, Appendix 3 – Spirit lamp test

2.1.1. Test pieces

2.1.1.1. Selection of test pieces

Samples of not less than 3 metres² shall be selected for test from material in sheet or roll form.

NOTE: Samples can be cut from the same 3 metres² sheet as supplied for tests C2 one-kilowatt-burner-flame test and C4 "Follow – Up" flame test

Six test pieces, 75 millimetres wide × 360 millimetres long shall be cut cleanly from the sample. Three test pieces shall be cut parallel to the length of the sheeting and three at right-angles to it. The test pieces shall be cut from places widely spaced from each other so that they are representative of the whole area of the sample of sheeting.

2.1.1.2. Conditioning test pieces

The test pieces shall be conditioned by free suspension at normal room temperature and humidity with both sides freely exposed to the atmosphere for at least 12 hours.

2.1.2. Apparatus

2.1.3. Spirit lamp

A methylated spirit lamp of minimum capacity 60 millilitres. The visible flame shall be 32 between 30 and 35 millimetres high measured from the top of the wick holder to the top of the flame.

The burner be supplied with IMS 95 methylated spirit.

2.1.3.1. Test stand

A suitable test stand shall be used (Figure 5 Experimental set up for the spirit lamp and follow up flame tests) consisting of a framework and clamps to hold the test piece in the required position during the test.

2.1.3.2. Cabinet

The test shall be carried out in a cabinet generally to the design and dimensions in Figure 3 Schematic diagram of cabinet. The inside of the cabinet shall be black.

A fume hood, with an extraction fan, may be positioned above the cabinet; the fan may be run during the test provided that it does not induce air movement through the cabinet additional to that required for the operation of the burner. Where this condition is not satisfied the fan shall be switched off during the test.

If required, additional close-fitting holes may be made in the cabinet to permit the entry of a remote handling device for the burner and the fuel pipe.

2.1.4. Procedure

- a) Tests shall be carried out in the test cabinet in subdued light.
- b) The test piece shall be suspended from the clamps so that it hangs vertically with its lower end held by horizontal clamps, one each side in such a way as to prevent movement of the test piece during the application of the flame (Figure 5). The lower edge of the clamps shall coincide with the lower edge of the test piece and overlap the sides by 13 millimetres.
- c) The flame is positioned so that the top of the wick holder is 20 millimetres below the middle of the lower edge of the test piece.
- d) Each test piece shall be held in the flame for 10 seconds and the lamp and flame shall then be withdrawn clear of the test piece.

2.1.5. Expression of results

- a) the time for all visible flame and glow to disappear from each of the six individual test pieces:
and
- b) the mean time for all visible flame and glow to disappear on the six test pieces.

Figure 5 Experimental set up for the spirit lamp and follow up flame tests

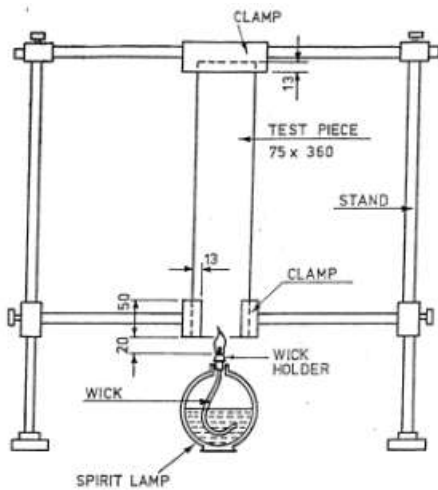

2.2. Requirements

The material shall fail the test where any of the following occur:

- a) mean persistence time of the flame of the six test pieces exceeds 6 seconds or if the persistence time of the flame of any one test piece exceeds 12 seconds;
- b) mean persistence time of the glow of the six test pieces exceeds 10 seconds or if the persistence time of the glow on any one test piece exceeds 30 seconds.

Should the material shrivel away such that the flame does not make contact with the material for the entire application time, the test shall be deemed invalid and the follow-up flame test shall be performed.

3. 'Follow-up' flame test

3.1. Method

This method has been adapted from the Appendices' of the National Coal Board Specification NCB 245:1985 Fire and electrical resistance properties of supported and unsupported sheeting, Appendix 4 – Follow up flame test.

NOTE: This test should only be performed where, during the spirit lamp test, the material shrivels away such that the flame does not make contact with the material for the entire application time and the test is deemed invalid.

The concept behind the test is to see whether, following simple low energy ignition, the sheeting will sustain combustion.

The reason for altering the "Follow-up" flame test in NCB 245:1985 Appendix 4 is because the method was biased against materials that shrivelled away from a flame. Using that method resulted in test samples not complying with the "completely consumed" criteria of the "Follow-up" flame test requirements. Since this characteristic of shrivelling away from a flame needed to be encouraged and not discouraged, the method was altered.

Therefore, instead of using six different exposure times, a single exposure time is selected prior to testing, and this is used for the six samples that are tested. Selection of the exposure time is detailed in the revised method.

To protect against approving materials that burn very rapidly, then the "completely consumed" criteria still remains part of the "Follow-up" flame test requirements.

3.1.1. Test pieces

3.1.1.1. Selection of test pieces

Samples of not less than 3 metres² shall be selected for test from material in sheet or roll form.

NOTE: Samples can be cut from the same 3 metres² sheet as supplied for tests C1 one kilowatt burner flame test and C2 spirit lamp test.

Six test pieces, 75 millimetres wide × 360 millimetres long shall be cut cleanly from the sample. Three test pieces shall be cut parallel to the length of the sheeting and three at right-angles to it. The test pieces shall be cut from places widely spaced from each other so that they are representative of the whole area of the sample of sheeting.

3.1.1.2. Conditioning test pieces

The test pieces shall be conditioned by free suspension at normal room temperature and humidity with both sides freely exposed to the atmosphere for at least 12 hours.

3.1.2. Apparatus

3.1.2.1. Spirit lamp

A methylated spirit lamp of minimum capacity 60 millilitres. The visible flame shall be between 30 and 35 millimetres high measured from the top of the wick holder to the top of the flame.

The burner be supplied with IMS 95 methylated spirit.

3.1.2.2. Test stand

A suitable test stand shall be used (Figure 5) consisting of a framework and clamps to hold the test piece in the required position during the test.

3.1.2.3. Cabinet

The test shall be carried out in a cabinet generally to the design and dimensions in Figure 3 Schematic diagram of cabinet. The inside of the cabinet shall be black.

A fume hood, with an extraction fan, may be positioned above the cabinet; the fan may be run during the test provided that it does not induce air movement through the cabinet additional to that required for the operation of the burner. Where this condition is not satisfied the fan shall be switched off during the test.

If required, additional close-fitting holes may be made in the cabinet to permit the entry of a remote handling device for the burner and the fuel pipe.

3.1.3. Procedure

The procedure shall be as follows:

1. Suspend the test piece in accordance with Appendix C2.1.3 and open the door of the cabinet up to 180 millimetres.
2. Insert a sample in the test stand and position the flame so that the top of the wick holder is 20 millimetres below the middle of the lower edge of the test piece.
3. Hold the lamp in a stationary position and record the time taken for the sample to shrivel away from the flame.
4. Repeat the above and record the mean time.
5. Select a test exposure time of either 15, 20, 25, 30, 45, and 60 seconds based on the next highest increment to the value recorded in step 4. (e.g. if the value recorded in step 4 was 22 seconds then the test exposure time would be 25 seconds.)
6. Insert a new sample in the test stand.

7. Hold and steadily raise the spirit lamp by hand so that the flame remains in contact with the test piece including char or slag (i.e. the material is not allowed to shrivel away from the flame).
8. Any char or slag shall not be removed during the test.
9. The lamp shall be removed after the exposure time (i.e. determined above). The persistence time of the flame and glow shall be measured.
10. Repeat the steps 6 to 9 for another five samples.

3.1.4. Expression of results

The following results shall be stated in the test report:

- a) the time for all visible flame and glow to disappear from the test piece at each of the six exposure times;
- b) the mean time for all visible flame and glow to disappear from the six test pieces, and
- c) whether the test piece is completely consumed at each of the six exposure times.

3.2. Requirements

The material shall fail the test where any of the following occur:

- a) the mean persistence time of the of the six test pieces exceeds 60 seconds or where the persistence time of the flame of any one test piece exceeds 80 seconds,
- b) mean persistence time of the glow of the six test pieces exceeds 60 seconds or where the persistence time of the glow on any one test piece exceeds 80 seconds, or
- c) the material is completely consumed.

4. Electrical resistance of flat surfaces test

4.1. Method

This method has been adapted from the Appendices' of the National Coal Board Specification NCB 245:1985 Fire and electrical resistance properties of supported and unsupported sheeting, Appendix 5 – Electrical resistance of flat surfaces test

4.1.1. Test pieces

Two test areas shall be prepared on the upper surface of the sample of sheeting and two on the lower surface. Each test area shall be not less than 300 millimetres × 300 millimetres.

4.1.2. Preparation of test pieces

4.1.2.1. Surface cleaning

The surfaces of the test areas shall be cleaned by dusting and rubbing with Fullers' Earth (BP technical grade) using a clean pad of cloth or wool. After all traces of powder have been cleaned away, the surfaces shall be wiped over with a clean pad moistened with distilled water and then rubbed dry with a clean cloth.

4.1.2.2. Application of electrodes

An electrode system shall be applied to each of the test areas. Each electrode system shall comprise two electrodes of soft, thin metal foil consisting of a circular disc 25 millimetres in diameter with a concentric annulus having internal and external diameters of 125 millimetres and 150 millimetres respectively as shown in Figure 6. Great care shall be taken to ensure accuracy of the dimensions of the electrodes, however the symmetry of the annulus about the centre disc is not critical.

The electrode system shall be applied centrally on the test area.

The electrode shall be attached to the test areas by a conducting liquid contact agent of:

- a) anhydrous polyethylene glycol of molecular weight 600: 4 parts by mass,
- b) soft soap, BP quality: 1/200 parts by mass, and
- c) water: 1 part by mass.

Liquid coatings of the same dimensions as the foil electrodes shall be formed on the surface. This may be conveniently accomplished with two felt pads of the same dimensions as the electrodes, moistened with the contact agent. The electrodes shall be rubbed on to the test surface with a finger or small soft pad. If the surface is indented, the foil electrodes shall, after rubbing, clearly follow the indentation. The contact agent shall not be smeared on the surface between the central disc and the annulus, however any small excess may be wiped away with a clean wool pad.

The foil electrodes may be omitted if the sheeting surface is sufficiently smooth and flat to enable the liquid contact agent to maintain continuous contact between the sheeting and the brass contact pieces, however with other surfaces such an omission can result in the indicated resistance being higher than the true resistance.

4.1.3. Apparatus

4.1.3.1. Measuring instrument

The resistance measuring instrument shall cover the range 1 M Ω to 10 G Ω and shall be accurate to within $\pm 5\%$ of the true value over this range. The potential applied to the electrodes under test shall be between 40 and 1000V dc and shall be chosen so not more than 1 watt is dissipated in the test piece.

4.1.3.2. Brass contact pieces

The brass contact pieces shall consist of a cylinder and a ring as dimensioned in Figure 6. The lower surface of each contact piece shall be machined flat and shall be polished and clean. Each contact piece shall be provided with a flexible insulated lead.

4.1.3.3. Polythene base

A clean sheet of polythene (or other material with resistance not less than that of polythene) not less than 2 mm thick and 300 millimetres \times 300 millimetres, shall be used.

4.1.4. Test procedure

The sample of sheeting shall be prepared and cleaned and without delay shall have the electrodes applied as described above. It shall immediately be placed for two hours in the following ambient conditions:

- a) temperature $20 \pm 2^\circ\text{C}$, and
- b) relative humidity $65 \pm 5\%$.

It shall then be tested without delay in the same ambient conditions.

NOTE: Non-compliance with the limit of resistance specified can be proved only under the above conditions, however compliance can be proved under any condition less than the upper limits of (a) and (b).

The polythene sheet shall be placed underneath the sample of sheeting immediately below the test areas and the brass contact pieces shall be mounted in position on the electrodes.

The leads from these contact pieces shall be taken direct to the measuring instrument so that the outer ring electrode is always connected to the earthed or low potential terminal and the inner cylinder to the higher potential terminal. These leads shall not touch each other, the sample of sheeting, or any part of the apparatus except the terminals to which each is connected. All terminals shall be connected to the same point.

The test potential from the measuring instrument shall be applied to the test area and the resistance shall be measured when a steady indication is obtained. The test potential shall be applied for not more than five minutes. Care shall be taken to avoid breathing on the test areas as any condensation of moisture on to these surfaces may lead to gross inaccuracies in the resistance measured.

The test shall be repeated in turn on the remaining three test areas.

Where a high degree of accuracy and reproducibility is required, for example in development work and laboratory calibration tests, the following requirements are recommended:

- i. The test area should be conditioned prior to the test for two hours at a temperature of $20 \pm 2^\circ\text{C}$ and relative humidity $65 \pm 5\%$. Care should thereafter be taken not to stress the test area during handling.
- ii. The temperature and humidity at which the tests are made should be controlled as closely as possible.
- iii. When working with an instrument for measuring a very high resistance range, an earthed metal base sheet covered with insulating material should be placed under the instrument and polythene base sheet.

It is not intended that these refinements should be used for routine production control and acceptance tests.

4.1.5. Expression of results

The following results shall be stated in the test report:

- a) the resistance measurement obtained for each test area:
- b) the average value of the two resistance measurements on the upper surface, and
- c) the average value of the two resistance measurements on the lower surface.

Figure 6 Dimensions of electrodes

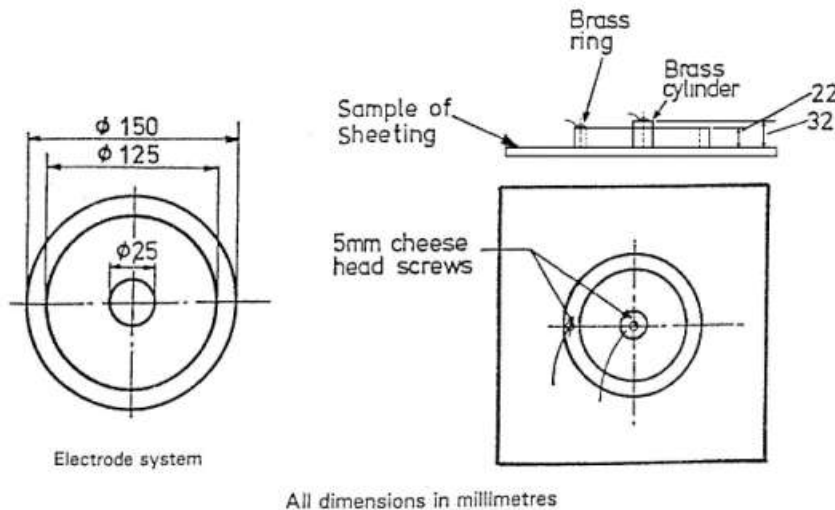

4.2. Requirements

The maximum value of the electrical resistance on both the upper and lower surfaces of the sheeting shall not be greater than 300 M Ω (megohms).

5. Electrical resistance of rigid pipes and rods test

5.1. Method

This method has been adapted from the National Coal Board Technical Memorandum No. RD/NMMB (84) 3 Anti-static requirement for rigid plastics pipe for underground use.

5.1.1. Principle of test

The electrical resistance of the pipe is measured between circumferential electrodes 100 mm apart.

5.1.2. Measuring instrument

The measuring instrument shall cover the range 10⁵ to 10¹⁰Ω and shall be accurate to within ± 5% of the true value over this range. The instrument shall supply to the electrodes under test a potential difference of between 40 and 1000 V d.c. The potential difference shall be such that not more than 1 watt is dissipated in the test piece.

5.1.3. Sampling

A representative sample of the pipe 2 metres long shall be supplied for test.

5.1.4. Test pieces

Five test pieces each consisting of a 300 millimetres length of pipe shall be cut from the sample supplied for test.

5.1.5. Preparation of test pieces

5.1.5.1. Surface cleaning

The surface of each test piece shall be cleaned by rubbing with Fullers Earth (BP technical grade) using a clean pad of cotton wool or cloth. After all traces of the powder have been cleaned away the surface shall be wiped with a clean pad of cotton wool moistened with distilled water and then rubbed dry with a clean cloth.

5.1.5.2. Application of electrodes

The electrodes shall be applied to each of the test pieces after surface cleaning treatment.

The electrodes shall be formed by two parallel circumferential bands of colloidal graphite (i.e. a colloidal solution of graphite in alcohol) or other conducting material painted on to the outside surface of the test piece. The resistance of the electrodes shall be such as to make no significant contribution to the measured resistance of the test piece. The electrodes shall be 25 mm wide and shall be positioned with their inner edges 100 millimetres apart and with their outer edges at equal distances from the ends of the test piece.

5.1.5.3. Contact pieces

The contact pieces shall be made from 25 millimetres wide strips of conducting metal foil. These shall be wrapped round the test piece in the same position as the electrodes. The free ends of the foil strip shall be held together and the strip lightly tensioned by means of a bulldog clip so that contact between the foil strip and the electrode is maintained round the complete circumference.

5.1.6. Test procedure

The test piece shall be prepared and cleaned and the electrodes and contact pieces applied as described above. The test piece shall then be placed for two hours in the following ambient conditions

- a) temperature $20 \pm 2^{\circ}\text{C}$, and
- b) relative humidity $65 \pm 5\%$

and shall then be tested without undue delay under the same conditions.

NOTE: Non-compliance with the requirements of this document can only be proved when the conditioning and testing are carried out at the temperature and humidity specified above. For routine purposes however compliance may be proved when the conditioning and testing are carried out at temperatures and humidities lower than those specified above.

The test piece shall be supported at each end on blocks of insulating material resting on a working surface of insulating material e.g. polythene. The insulating blocks shall provide resistance of at least 1011Ω between the test piece and the working surface. The resistance of the blocks and working surface may be maintained by periodic cleaning with Fuller’s earth as described above.

The leads from the testing instrument shall be connected to the contact pieces and shall not touch each other or any part of the test piece. The test potential shall be applied to the test piece and the resistance measured as soon as a steady indication is obtained. The test potential shall be applied for not more than five minutes. Care shall be taken to avoid breathing on the test piece while the test potential is applied.

One observation of resistance shall be made on each of the five test pieces.

5.1.7. Expression of results

The following shall be reported:

- a) The measured outside diameter of the pipe D in millimetres.
- b) The observed resistance in ohms of each of the five test pieces.
- c) The upper limit of resistance, R_{Max}, required by this document calculated from

$$R_{Max} = \frac{7.5 \times 10^9}{D} \quad (\text{in } \Omega)$$

where D is the measured outside diameter in millimetres.

5.2. Requirements

Each of the five observations of electrical resistance shall not exceed $7.5 \times 10^9/D \Omega$, where D is the measured outside diameter of the pipe in millimetres.

6. Air permeability of brattice test

6.1. Method

This method has been adapted from the National Coal Board Specification NCB 441:1964 Brattice sheeting made from textile supported plastics Appendix 4.

6.1.1. Test pieces

Five test pieces, 160 × 160 millimetres, shall be cut from the sample supplied for test.

6.1.2. Apparatus

A schematic diagram of the experimental apparatus is shown in Figure 7.

Figure 7 Experimental apparatus for air permeability test

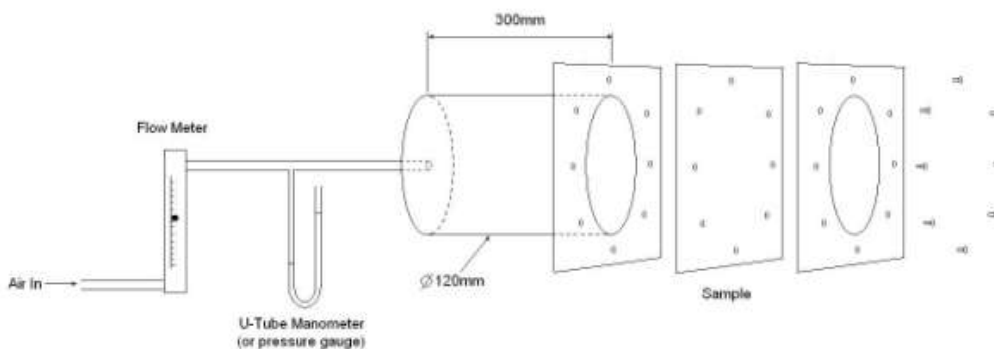

Procedure

- a) Secure the sample between the two faceplates and secure with screws. A suitable sealant material may be used between the faceplates to ensure no leakage.
- b) Adjust the air supply to provide a pressure of 1.24 kPa (127 mm H2O).
- c) Read flow rate from the flowmeter.
- d) Calculate the air flow from the following equation and convert units to Ls-1m-2.

$$F = \frac{F_{Measured}}{Area}$$

6.2. Requirement

The air flow shall not be greater than 25.4 Ls-1m-2.

7. Toxicity testing

7.1. Method

Products shall be tested to ISO/TS 19700 Controlled equivalence ratio method for the determination of hazardous components of fire effluents.

NOTE: This test shall be carried out before any gallery or friction testing is undertaken, as applicable.

Fire effluent shall be tested for the following types of fire (from ISO/TS 19706:2004, Table1):

- Stage 1. Non flaming
- Stage 2. Well ventilated flaming
- Stage 3. Less well-ventilated flaming

Results from the testing shall be scaled to represent the concentrations that 100 g of material would emit into a 1 metre³ volume. The Toxicity Index for each fire type as calculated using the 30-minute fatal exposure concentrations per Allied Fire Assessment Publication 3 (AFAP-3) shall be less than or equal to ten (≤10).

The toxicity index TI is calculated as follows:

$$TI = \sum \frac{C_1}{Cf_1} + \frac{C_2}{Cf_2} + \frac{C_3}{Cf_3} + \dots \dots \dots \frac{C_n}{Cf_n}$$

Where

Cn = the concentration of gas n

Cfn = the concentration of the gas considered fatal to a person for a 30-minute exposure (Critical factor)

Critical Factors are in the table below.

Gas	Formula	Cf (ppm)
Carbon Dioxide	CO ₂	100000
Carbon Monoxide	CO	4000
Oxides of Nitrogen	NO _x	100
Sulphur Dioxide	SO ₂	400
Hydrogen Fluoride	HF	50
Hydrogen Bromide	HBr	150
Hydrogen Chloride	HCl	500
Hydrogen Cyanide	HCN	90
Phenol	C ₆ H ₅ OH	250
Formaldehyde	HCHO	500
Acrolein	CH ₂ CHCHO	5

NOTE: Phenol, Formaldehyde and Acrolein need only be determined where the Toxicity Index for the other components is greater than 7.

7.2. Requirements

For each of the fire types, the toxicity indices shall be less than 10.

Where the toxicity index is greater than ten, the data from the ISO/TS 19700 assessment may be used in ISO 13444 Estimation of lethal toxicity of fire effluents and ISO 13571 Life threatening components of fire – Guidelines for the estimation of time available for escape using fire data as part of a fire safety risk analysis. The risk analysis would also have to consider models for the analysis of the initiation and development of fire, fire spread and smoke formation. The risk analysis results may influence design of the mine and its ventilation.

8. Spark incendivity

8.1. Method

NOTE: This test is adapted from IEC 61340-4-4 for materials that do not comply with surface resistance testing.

8.1.1. Test piece

For testing of the FRAS product, a sample size should be used of between 0.1 to 0.5 metres².

For testing of a manufactured unit, a completed sample of the manufactured unit shall be supplied with all attachments required for the intended use in the mine environment, e.g. for lay flat ventilation ducting designed to be suspended using eyelets, all eyelets shall be fitted.

8.1.2. Apparatus

- a) An ignition probe and gas control equipment that meets Clause 7.2 of IEC 61340-4-4.
- b) Supplies of air and ethylene.

- c) Equipment to apply a static charge to the sample in excess of 30 kV (e.g. van de Graff Generator)
- d) Non-metallic test stand to support the sample.

NOTE: Metal objects and components may adversely affect the test and should be at least 1m away from the sample during testing.

8.1.3. Ambient conditions

The test shall be conducted in the following ambient conditions:

- a) temperature $23 \pm 2^{\circ}\text{C}$, and
- b) relative humidity $50 \pm 5\%$.

8.1.4. Test procedure

For testing of a manufactured product that is fitted with highly conductive attachments such as eyelets, rivets, bolts, etc, each conductive attachment shall be tested for spark ignition in accordance with the following procedure. This test is not required where all attachments are electrically bonded to the earthing connection point .,

Items that are designed to be earthed in normal use shall be earthed using the earthing facility provided with the sample. Items that are designed not to be earthed in normal use shall not be earthed.

The procedure shall be as follows:

- a) Hang the test piece from the support stand.
- b) Connect any earth bonds in accordance with the manufacturer's directions.
- c) Apply an electric charge to the sample.
- d) Apply gas to the probe for 30 secs and move the probe to approach the sample at a rate of approximately 0.1 metres/second until it touches the sample.

Note: 0.1m/s speed is used due to potential gas displacement when test is conducted at a higher speed

- a) Where the gas ignites, the test is recorded as an ignition and failure.
- b) Repeat the test:
 - i. 50 times each side of flat samples, or
 - ii. a total of 100 times for other samples, or
 - iii. until ignition occurs.

8.2. Requirements

There shall be no ignition of the test gas from the test material.

If there are metallic or conductive attachments fitted to the material that are not bonded to the earthing point, there shall be no ignition of the test gas from the metallic or conductive attachments.